



Bill Acceptor

# A6 / V6

Installation Guide *Series*

International Currency Technologies Corp.

## ***Use of Materials Limitations***

International Currency Technologies Corporation (ICT) all rights reserved.

All materials contained are the copyrighted property of ICT.

All trademarks, service marks, and trade names are proprietary to ICT.

ICT reserves the right at all times to disclose or to modify any information as ICT deems necessary to satisfy any applicable law, regulation, legal process or governmental request, or to edit, refuse to post or to remove any information or materials, in whole or in part, in ICT's sole discretion.

# Contents

<b>1. Introduction</b>	
1-1. Overview .....	2
1-2. Features .....	2
<b>2. Specifications</b> .....	2
<b>3. Packing List</b> .....	3
<b>4. Dimension</b> .....	4
4-1. Bezel Styles .....	6
<b>5. Installation</b>	
5-1. Harness Application .....	9
5-1-1. I/O Circuit .....	19
5-2. DIP Switch Setting .....	23
5-3. Software Download and Upgrade .....	23
<b>6. Maintenance</b> .....	24
<b>7. Troubleshooting</b> .....	25

## 1. Introduction

### 1-1. Overview

A6/V6 Series is a bill acceptor which features not only high-security module with bill box but also outstanding recognition, acceptance rate up to 96% or even greater.

### 1-2. Features

- Four way bill insertion acceptance.
- Auto-calibrating.
- Numerous interfaces available.
- Easily Install & Maintain.

## 2. Specifications

### *General*

Acceptance Rate	96 % or greater
Bill Insertion	Four way acceptable
Transaction Speed	Approx. 3 seconds to stack
Interface	<b>A6-</b> STD Pulse, 5V ENABLE, ICT Protocol, Single price. <b>V6-</b> MDB

### *Electrical*

Power Source	<b>A6-</b> 12V DC(11.4~12.6V DC) 117V AC(105.3~128.7V AC) <b>V6-</b> 24V/34V DC(20V~42.5V DC)
--------------	---

Power Consumption	<b>A6-</b> 12V DC	Standby : 0.3A, 4W Operation: 0.9A, 11W Maximum: 2.6A, 32W
	117V AC	Standby : 0.06A, 7W Operation: 0.112A, 14W Maximum: 0.4A, 47W
	<b>V6-</b> 24V/34V DC	Standby : 0.15A, 6W Operation: 0.4A, 14W Maximum: 1.35A, 46W
Operation Environment	Operation Temperature: 0°C~55°C Storage Temperature : -30°C~70°C Humidity: 30%~85% RH(no condensation)	

### ***Mechanical***

Bill Capacity	Approx. 100 bills( 40~ 140) 300 bills( 200~ 300) 500 bills( 300~ 500) 550 bills( 440~ 640) 800 bills( 750~ 850) 1000 bills(1000~1140)
Bill Width Accepted	60~67 mm
Weight	Approx. 2kg(shipping)
Installation	Indoor

## **3. Packing List**

Main	Bill Acceptor
Accessory	Harnesses: Refer to 5-1 A6/V6 Installation Guide A6/V6 Switches Setting Guide

## 4. Dimension

### Vertical

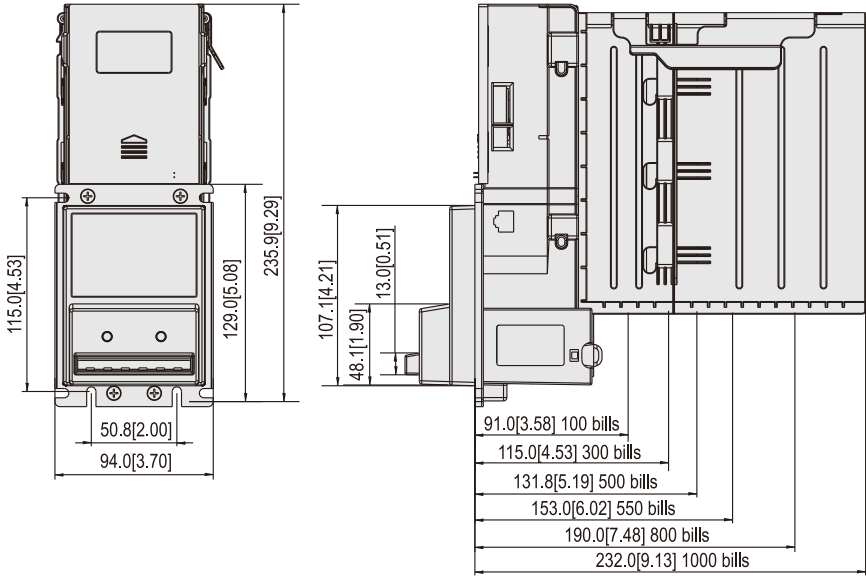

Unit : mm [inch]

4 FIG. 01

Horizontal

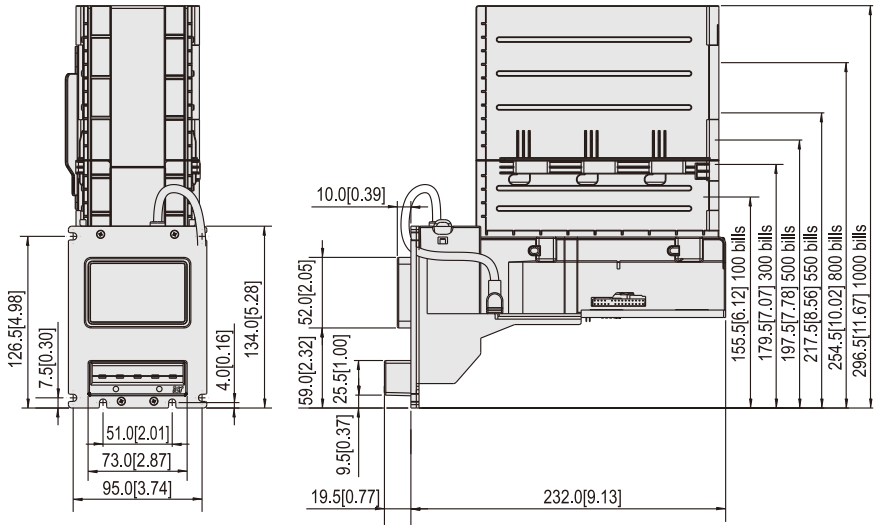

Unit : mm [inch]

4 FIG. 02

## 4-1. Bezel Styles

### Standard bezel

Part Number: 3RMB-FAC01001

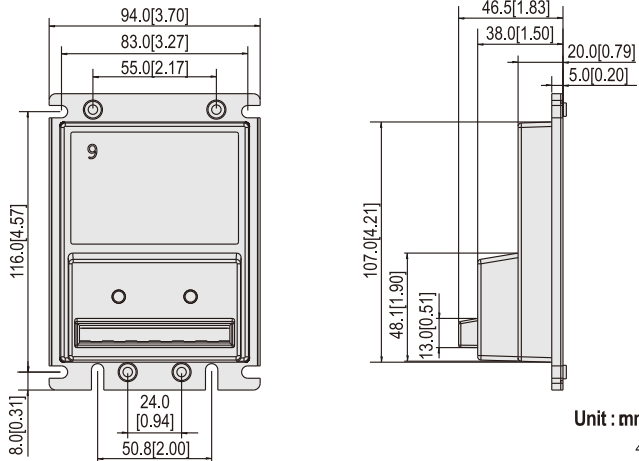

Unit : mm [inch]

4-1 FIG.01

### Fitted bezel

Part Number: 3RMB-FAC02000

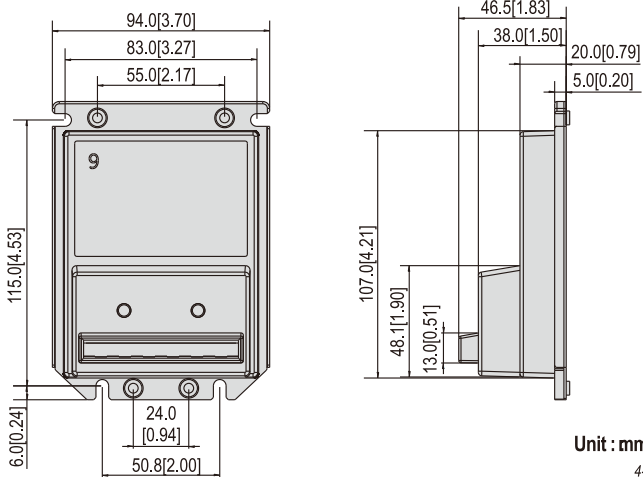

Unit : mm [inch]

4-1 FIG.02



**Anti-coin Bezel**

Part Number: 3RMB-FAC16002

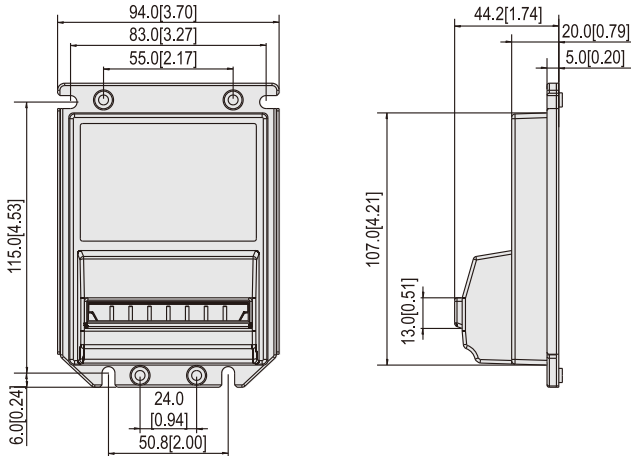

Unit : mm [inch]

4-1 FIG.03

**Horizontal Bezel**

Part Number: 3RMB-FAC10000

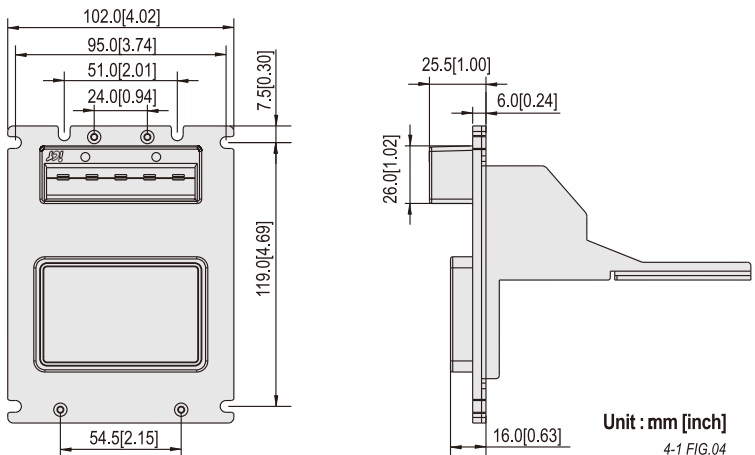

Unit : mm [inch]

4-1 FIG.04

**For VFM bezel**

Part Number: 3RMB-FAC23000

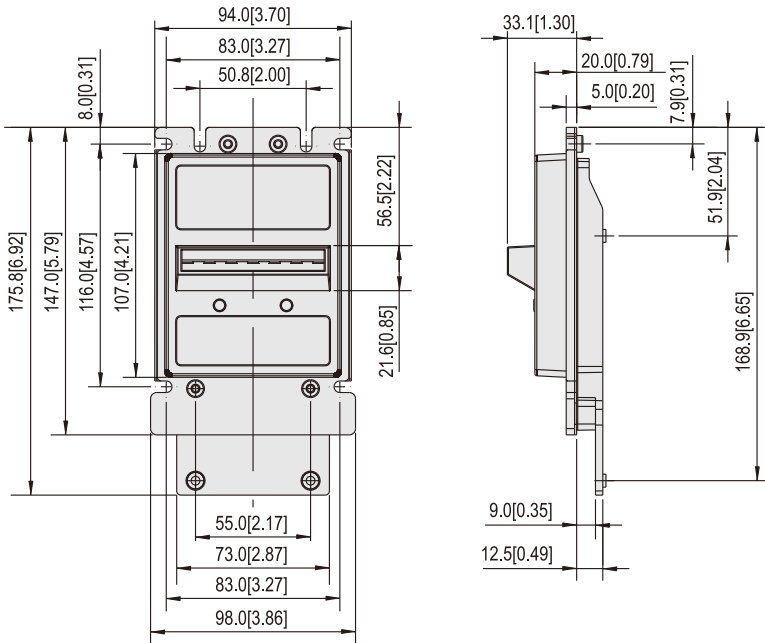
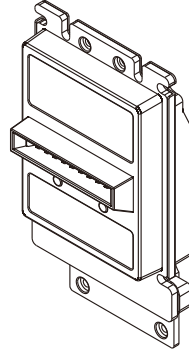
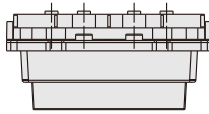

**Unit : mm [inch]**

4-1 FIG.05

## 5. Installation

### 5-1. Harness Application

5-1 TABLE 01

Model	Interface	Used Voltage	Usage	Harness	Page
<b>A6</b>	STD Pulse	117V AC	Power & *Data Comm.	WEL-RM008	10
			Extension Wire	WEL-RM012	11
		12V DC	Power & *Data Comm.	WEL-RM007	12
			Extension Wire	CU-R961-1	13
	5V Enable	117V AC	Power & *Data Comm.	WEL-RM017	14
			Extension Wire	WEL-RM018	15
	ICT Protocol (RS232)	12V DC	Power	WEL-RM007	12
			Extension Wire	CU-R961-1	13
			*Data Comm.	WEL-RV706-1 or 2-BA-RV706	16
		117V AC	Power	WEL-RM008	10
			Extension Wire	WEL-RM012	11
			*Data Comm.	WEL-RV706-1 or 2-BA-RV706	16
	Single Price	117V AC	Power & *Data Comm.	WEL-RM031	18
<b>V6</b>	MDB	24V/34V DC	Power & *Data Comm.	WEL-RM006	17

\*Data Comm. : Data Communication.

5-1 FIG.01

Interface	Used Voltage	Usage
STD Pulse	117V AC	Power & *Data Comm.
ICT Protocol (RS232 )	117V AC	Power

## WEL-RM008

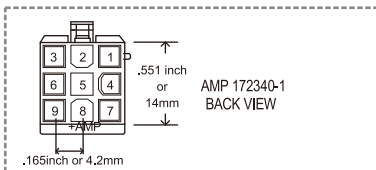
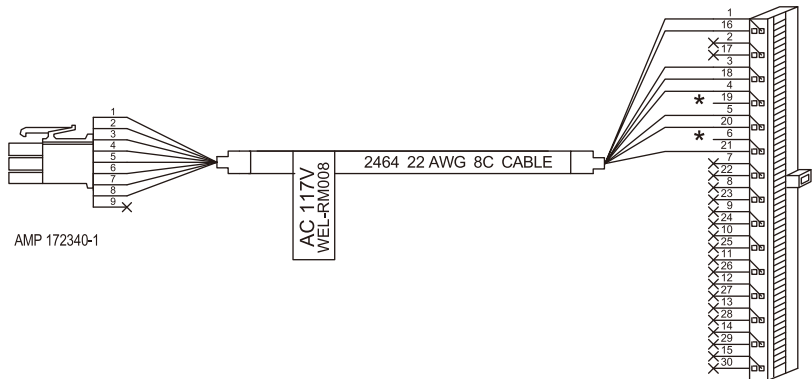

- PIN 1- YELLOW.....NEUTRAL INHIBIT
- PIN 2- RED.....NEUTRAL ENABLE
- PIN 3- BROWN.....HOT ENABLE
- PIN 4- BLACK.....117VAC HOT(Power)
- PIN 5- GREEN.....Earth-Ground
- PIN 6- WHITE.....117VAC NEUTRAL(Power)
- PIN 7- BLUE.....CREDIT\_RELAY(N.O.)
- PIN 8- PURPLE.....CREDIT\_RELAY(Common)

- PIN 1- PURPLE.....CREDIT\_RELAY(Common)
- PIN 3- RED.....NEUTRAL ENABLE
- PIN 4- WHITE.....117VAC NEUTRAL(Power)
- PIN 5- YELLOW.....NEUTRAL INHIBIT
- PIN 16- BLUE.....CREDIT\_RELAY(N.O.)
- PIN 18- BROWN.....HOT ENABLE
- PIN 20- BLACK.....117VAC HOT (Power)
- PIN 21- GREEN.....EARTH GROUND

5-1 FIG.02

Interface	Used Voltage	Usage
STD Pulse	117V AC	Extension Wire for WEL-RM008
ICT Protocol (RS232 )	117V AC	Extension Wire for WEL-RM008

### WEL-RM012

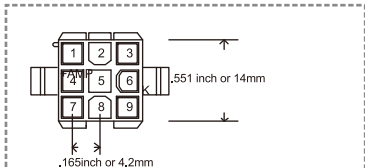
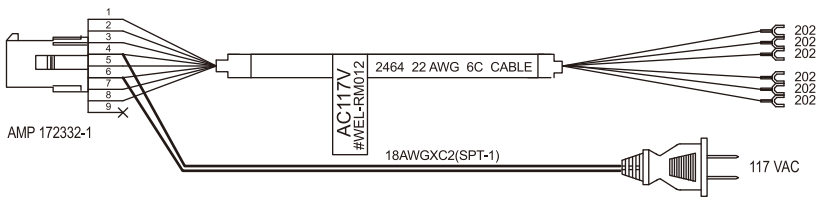

AMP 172332-1 BACK VIEW

- PIN 1- YELLOW.....NEUTRAL INHIBIT
- PIN 2- RED.....NEUTRAL ENABLE
- PIN 3- ORANGE.....HOT ENABLE
- PIN 4- BLACK.....17VAC HOT (Power)
- PIN 5- GREEN.....Earth - Ground
- PIN 6- BLACK.....117VAC NEUTRAL (Power)
- PIN 7- BLUE.....CREDIT\_RELAY (N.O.)
- PIN 8- PURPLE..CREDIT\_RELAY (Common)
- PIN 9- Reserved

- YELLOW.....NEUARAL INHIBIT
  - RED.....NEUTRAL ENABLE
  - ORANGE.....HOT ENABLE
  - GREEN.....Earth - Ground
  - BLUE.....CREDIT\_RELAY (N.O.)
  - PURPLE.....CREDIT\_RELAY (Common)
- 202

5-1 FIG. 03

Interface	Used Voltage	Usage
STD Pulse	12V DC	Power & *Data Comm.
ICT Protocol (RS232)	12V DC	Power

WEL-RM007

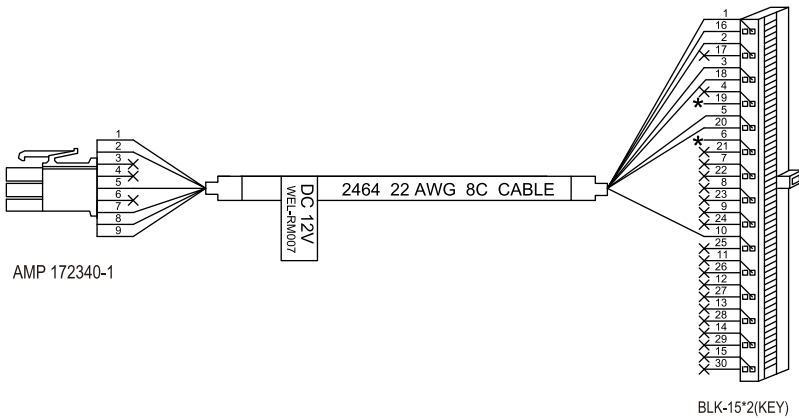

- PIN 1- YELLOW.....INHIBIT+
- PIN 2- GREEN.....INHIBIT-
- PIN 3- RESERVED
- PIN 4- RESERVED
- PIN 5- RED.....12V DC (POWER)
- PIN 5 DOTTED- BLACK.....12V DC (POWER)
- PIN 6- RESERVED
- PIN 7- BLUE.....CREDIT\_RELAY (N.O.)
- PIN 8- PURPLE.....CREDIT\_RELAY (COMMON)
- PIN 9- BROWN.....GND (POWER)
- PIN 9 DOTTED- WHITE.....GND (POWER)

- PIN 1- PURPLE.....CREDIT\_RELAY (COMMON)
- PIN 2- RED.....12VDC (POWER)
- PIN 3- WHITE.....ENABLE-
- PIN 5- YELLOW.....INHIBIT+
- PIN 10- BROWN.....GND (POWER)
- PIN 16- BLUE.....CREDIT\_RELAY (N.O.)
- PIN 18- BLACK.....ENABLE+
- PIN 20- GREEN.....INHIBIT-

5-1 FIG. 04

Interface	Used Voltage	Usage
STD Pulse	12V DC	Extension Wire for WEL-RM007
ICT Protocol (RS232)	12V DC	Extension Wire for WEL-RM007

### CU-R961-1

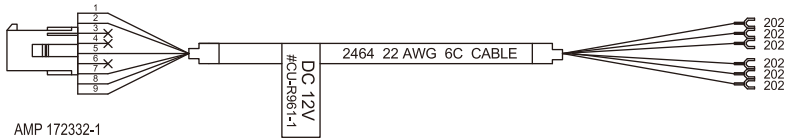

AMP 172332-1

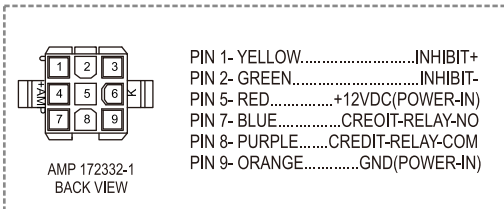

Interface	Used Voltage	Usage
5V Enable	117V AC	Power & *Data Comm.

### WEL-RM017

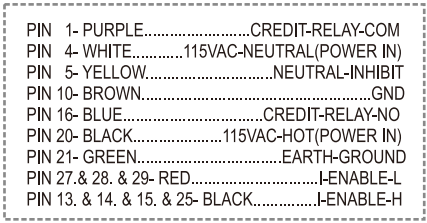
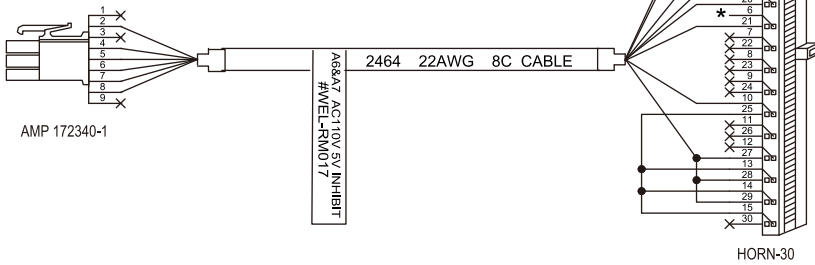
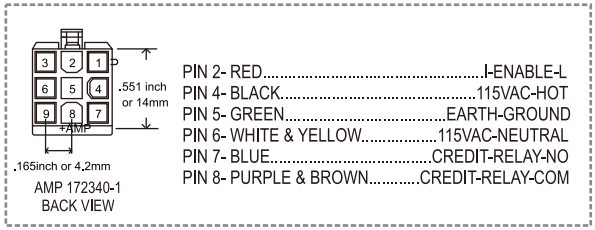



5-1 FIG. 06

Interface	Used Voltage	Usage
5V Enable	117V AC	Extension Wire for WEL-RM017

### WEL-RM018

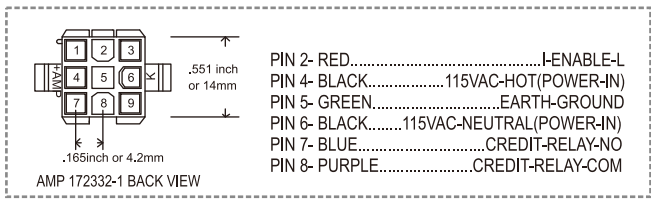
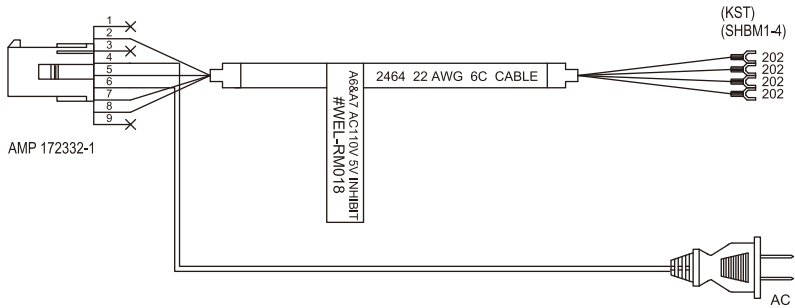

5-1 FIG. 07

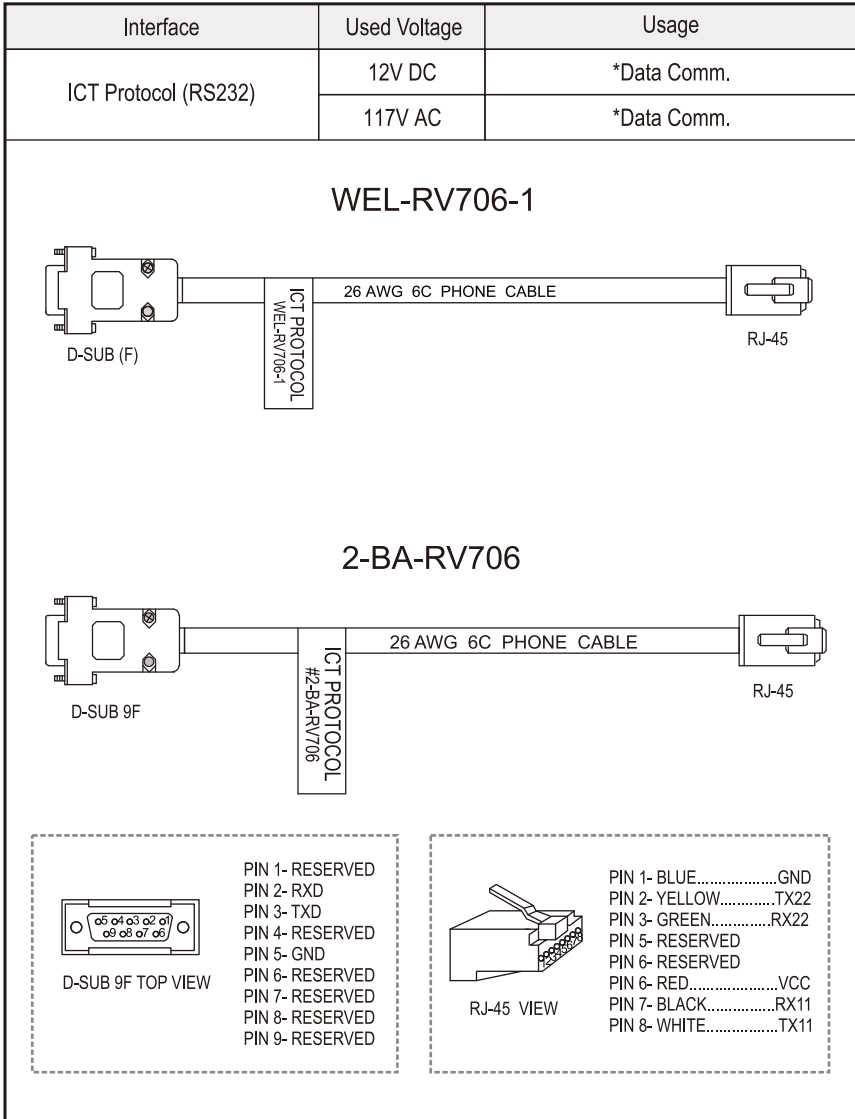

5-1 FIG. 08

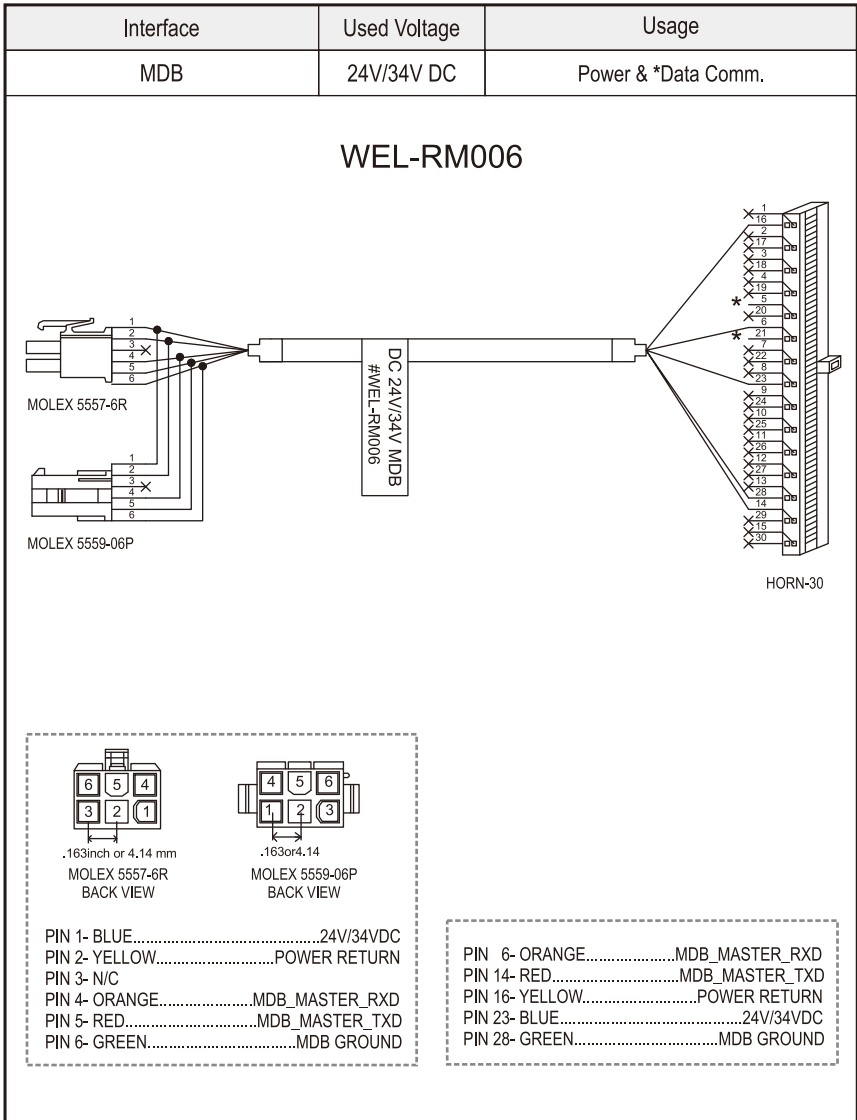

Interface	Used Voltage	Usage
Single price	117V AC	Power & *Data Comm.

## WEL-RM031

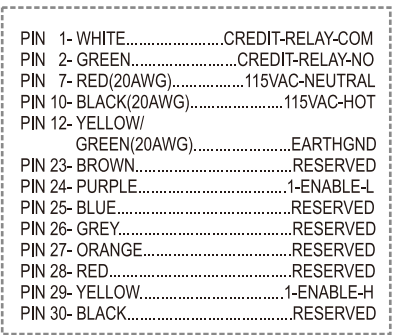
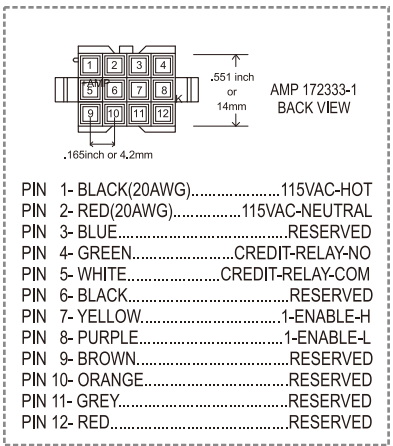
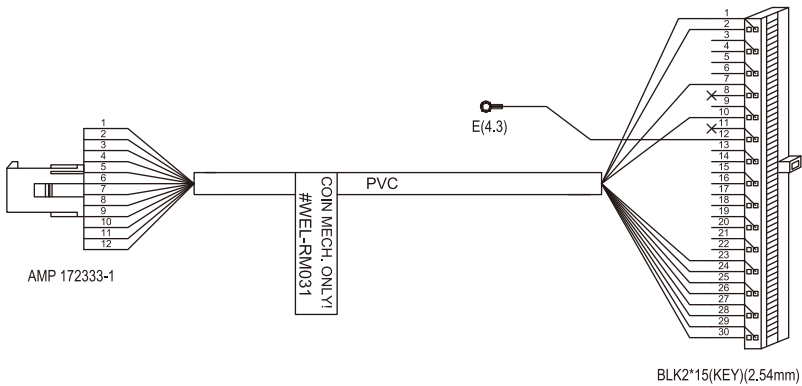

5-1-1. I/O Circuit

Pulse Interface

5-1-1 FIG. 01

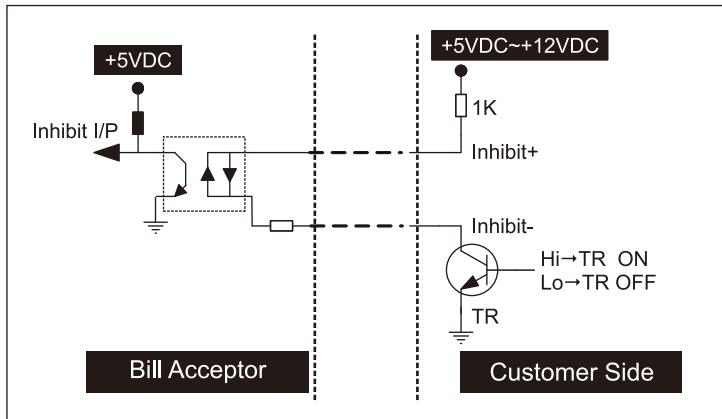
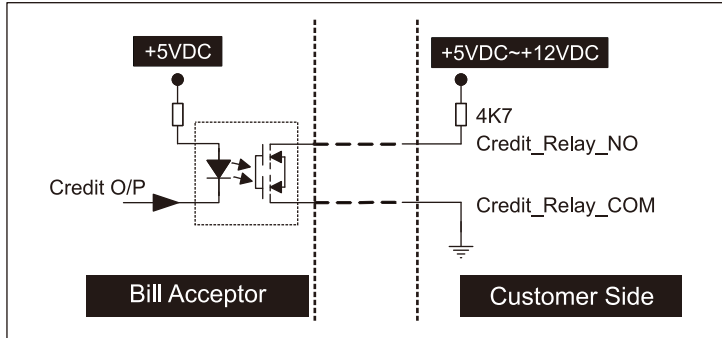

MDB Interface

5-1-1 FIG. 02

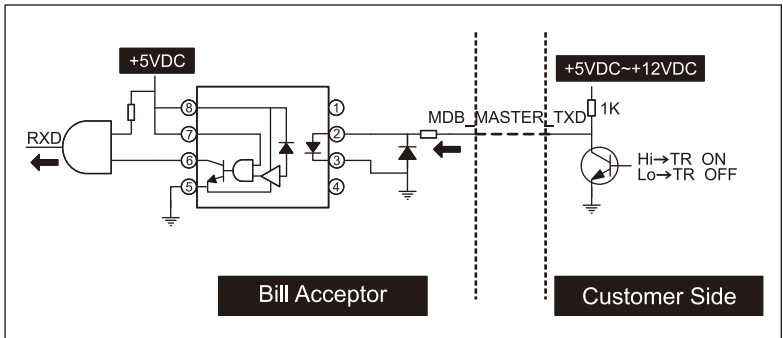
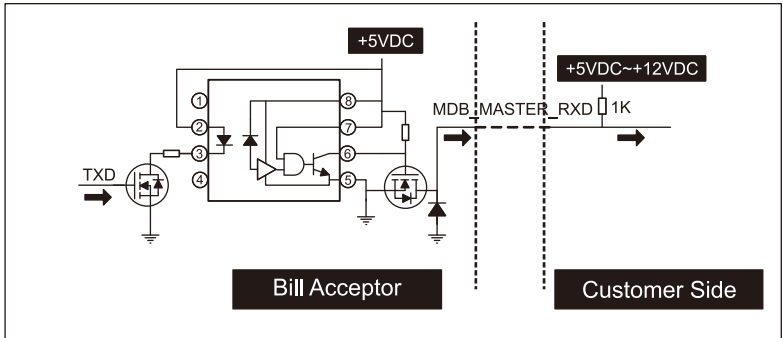

5V Enable Interface

5-1-1 FIG. 03

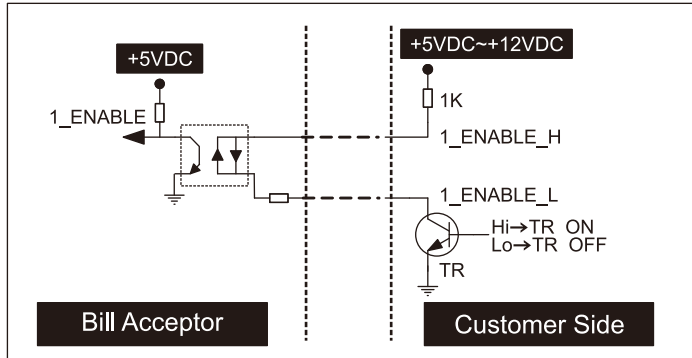

ICT-Protocol Interface

5-1-1 FIG. 04

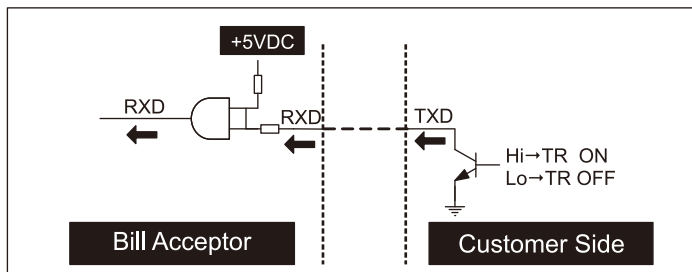
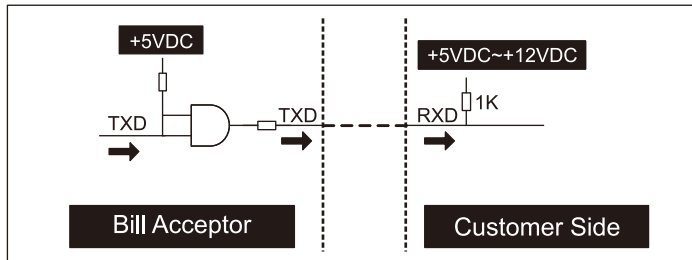

Single Price Interface.

5-1-1 FIG.05

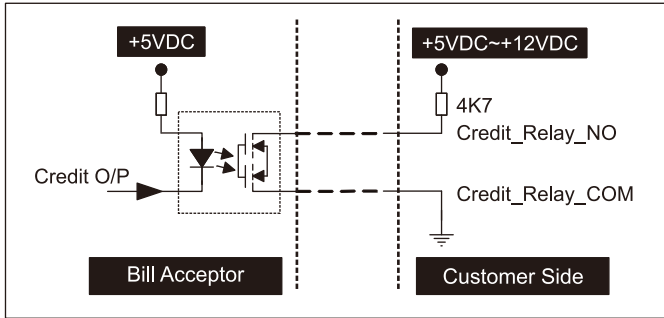



## 5-2. DIP Switch Setting

There are two serial DIP switches which are set on the side of A6/V6 series (as FIG.01). According to different currencies which are used by users, DIP switch settings could be varied to fit users' needs. There is also a serial DIP switch on the base of the unit for inside interface settings (as FIG.02). Please refer to "A6/V6 series DIP Switch Setting Guide" in the package for more details.

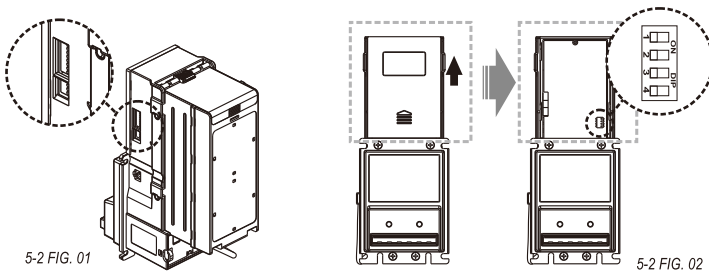

## 5-3. Software Download and Upgrade

To download and upgrade the software to A6/V6 Series, the programmer (FP-004) is needed. Please contact ICT to purchase FP-004 and refer to FP-004 user guide for software download and upgrade information.

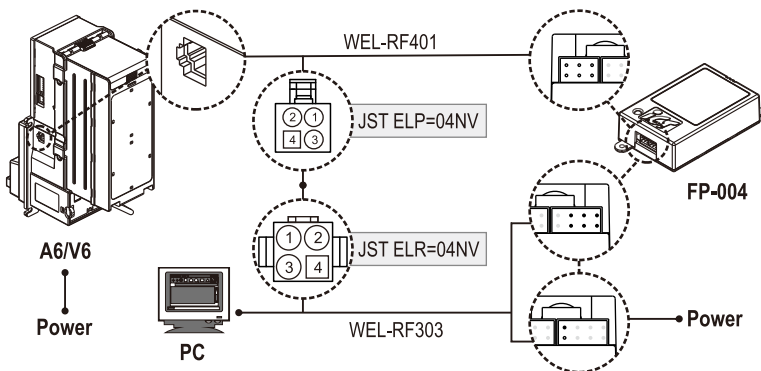

Power must be applied to Bill Acceptor **after** connecting.

## 6. Maintenance

To make sure the bill acceptor always works smoothly, please clean the internal parts every two weeks to every two months.

To clean the internal parts:

1. Press the buttons on the sides of bill path unit and pull the unit out.

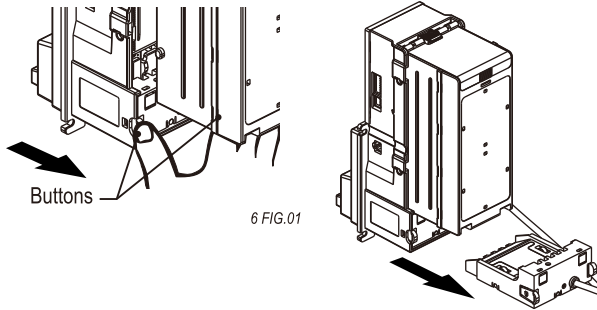

2. Use a soft, dry cloth or towel to clean the bill path and sensors.

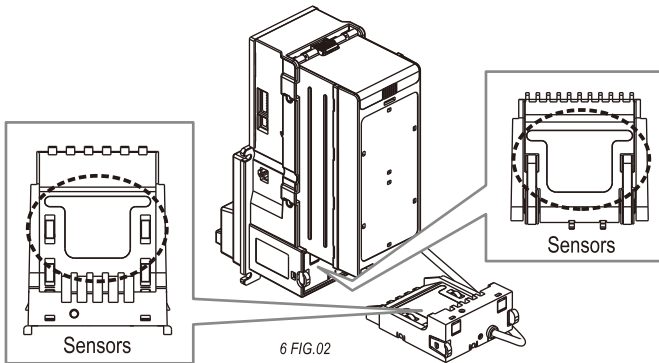

	<b>Maintenance Notice</b>	
	<i>(Any improper maintenance will invalidate the warranty.)</i>	
	<b>Recommended</b>	<b>Mild, non-abrasive, soap water.</b>
	<b>DO NOT USE</b>	<b>Organic solvent , Alcohol, Volatile liquid.</b>

## 7. Troubleshooting

7 TABLE 01

LED	Status	Corrective Actions
Green	White Card Calibration.	Please calibrate with ICT white calibration card.

7 TABLE 02

LED Flashes (Green)	Status	Corrective Actions
1	Bill jammed.	Remove the bill box by sliding the top button and the bill path unit (as 7 FIG.01), and then remove the jammed bill.
2	Disable	Inspect for right DIP switch setting.
3	Recognition sensor error.	Inspect for foreign objects on sensor or bill path and clean.
3+2	Hook sensor error.	Inspect for foreign objects on security hook and clean.
5	Bill box has been removed.	Replace the bill box.
6	Stacker error or stacker full.	Empty the bill box.
7	Motor error.	Inspect for foreign objects on bill path and clean.

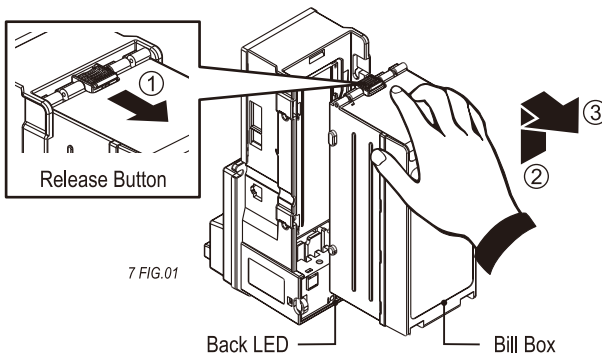

**If the error can not be solved after corrective actions or happen again, please contact ICT for technical support.**



**ict** Taiwan

**International Currency Technologies Corporation**

No.28, Ln. 15, Sec. 6, Minguan E. Rd., Neihu Dist., Taipei City 114, Taiwan

[sales@ictgroup.com.tw](mailto:sales@ictgroup.com.tw) (For Sales)

[fae@ictgroup.com.tw](mailto:fae@ictgroup.com.tw) (For Customer Service)

Website: [www.ictgroup.com.tw](http://www.ictgroup.com.tw)

