

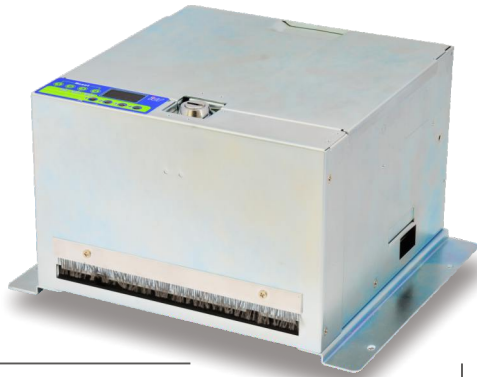

Note Dispenser
NDE 1000



Installation Guide

Use of Materials Limitations

International Currency Technologies Corporation (ICT) all rights reserved.

All materials contained are the copyrighted property of ICT.

All trademarks, service marks, and trade names are proprietary to ICT.

ICT reserves the right at all times to disclose or to modify any information as ICT deems necessary to satisfy any applicable law, regulation, legal process or governmental request, or to edit, refuse to post or to remove any information or materials, in whole or in part, in ICT's sole discretion.

Contents

1. Introduction	
1-1. Overview	2
1-2. Features	2
2. Specifications	2
3. Packing List	3
4. Dimension	4
5. Installation	
5-1. Harness Application	6
5-1-1. I/O Circuit	11
5-2. Key Function	13
5-3. DIP Switch Setting	17
5-4. Software Download and Upgrade	
5-4-1. ICT FP-004 Programmer Firmware Upgrade	17
5-4-2. USB Pen Drive Firmware Upgrade	18
5-4-3. ICT MTB Firmware Upgrade	19
6. Operation	
6-1. Unusable Note	21
6-2. How to Fill Notes	23
6-3. Low Level Adjustment	24
7. Maintenance	25
8. Troubleshooting	
8-1. Errors Messages	26

1. Introduction

1-1. Overview

NDE1000 , a compact size with up to 1000 banknotes capacity, is designed able to dispense versatile notes released from worldwide countries via a built-in study mode. With LCM display and operation key-pad, NDE1000 is very easy to use for the user no matter on settings, operations or troubleshooting.

1-2. Features

- A wide-range voltage power-input.
- Easy and convenient firmware download via USB pen drive.
- Easy operation and settings via digital display with key pad.
- Security lockable cashbox.
- Compact design to save installation space.
- Identify and dispense worldwide currencies through a built-in study mode.

2. Specification

General

Dispensing Speed	Approx. 2.5 notes per second
Interface	Pulse, RS232, Hopper, ICT Protocol

Electrical

Power Source	DC12~24V
---------------------	----------

Power Consumption	DC 12V- Standby : Approx. 0.1A, Operation: Approx. 1.8A, Maximum: Approx. ≤4.5A DC 24V- Standby : Approx. 0.1A, Operation: Approx. 1A, Maximum: Approx. ≤3.5A
Operation Environment	Operation Temperature: 0°C~55°C Storage Temperature: -30°C~70°C

Mechanical

Bill Capacity	Suggested capacity around 500 notes.
Bill Accepted Width	(W) 62~77 mm (L) 120~160 mm (T) 0.08~0.125 mm
Weight	Approx. 5kg
Installation	Indoor

3. Packing List

Main	Note Dispenser
Accessory	Harnesses: Refer to page. 6 NDE1000 Installation Guide

4. Dimension

Standard

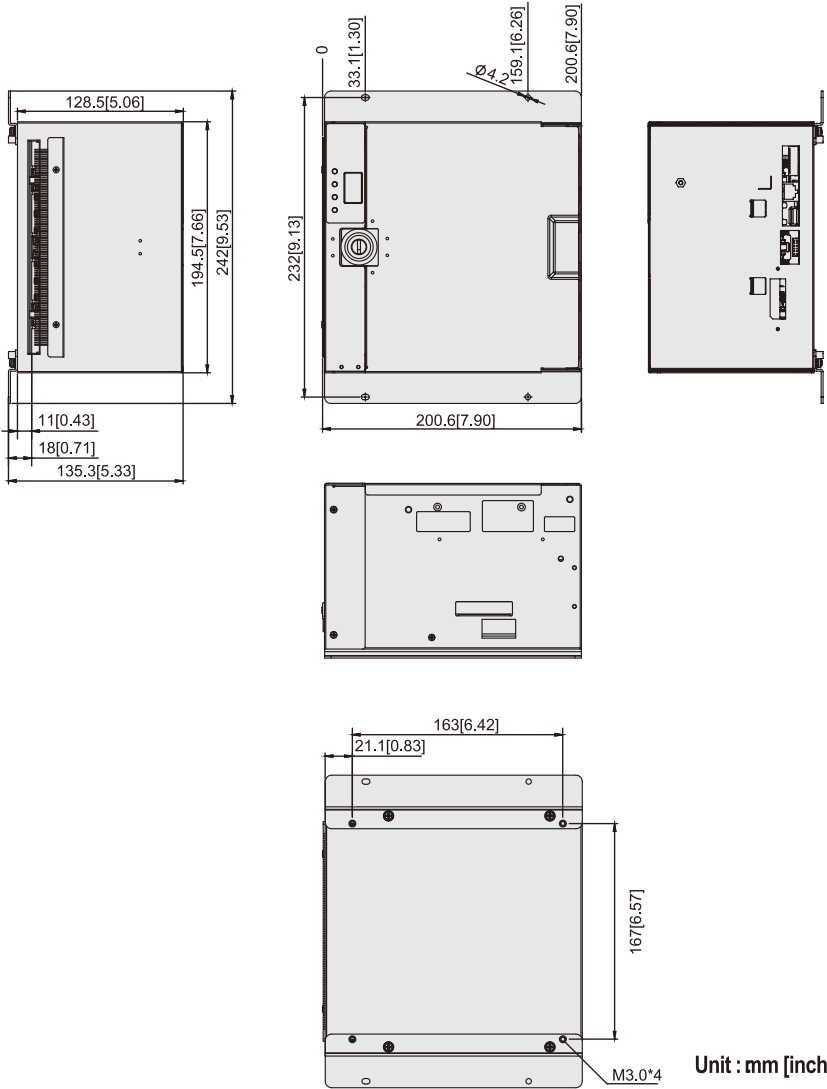

JAE connector (Optional)

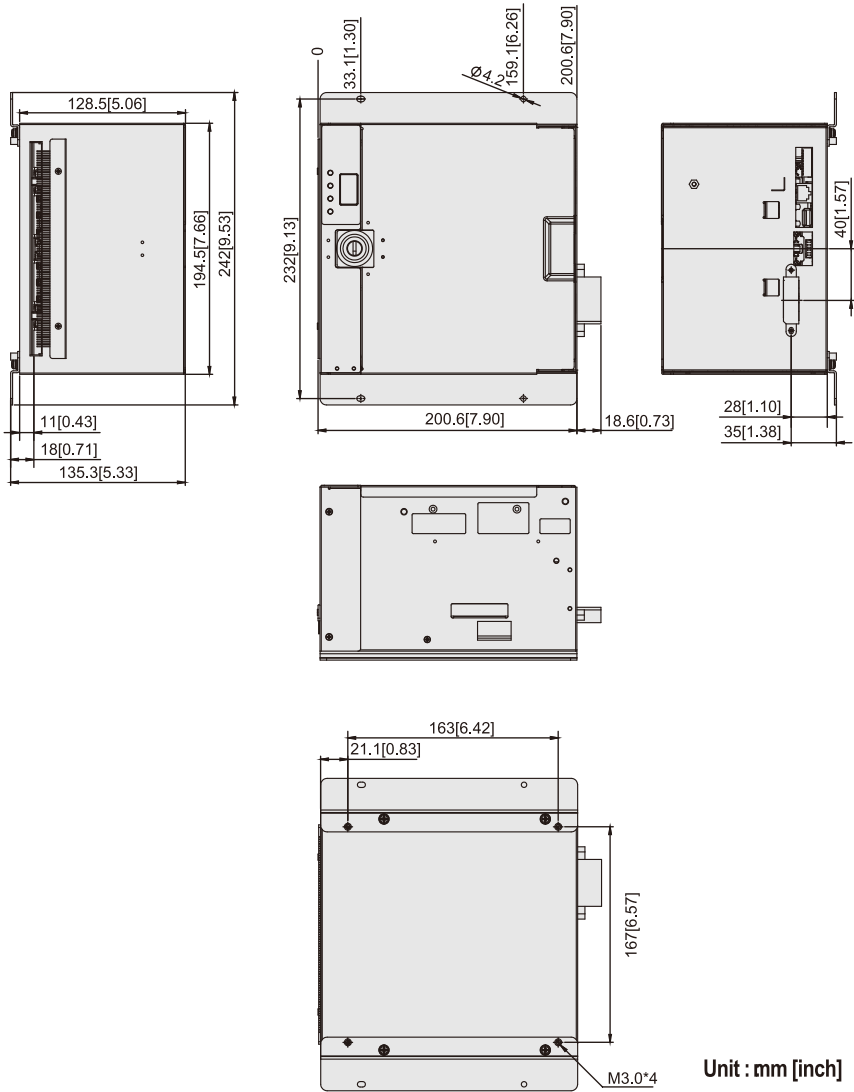

Unit : mm [inch]

4 FIG.02

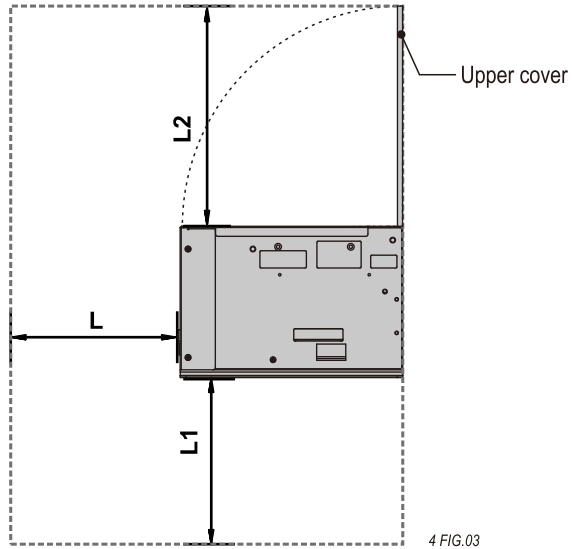

Please follow instructions below before installing NDE1000:
 [L]: the distance from the note mouth: 150mm or above.
 [L1]: the distance from NDE1000 bottom: 150mm or above.
 [L2]: the distance from NDE1000 upper: 200mm or above.

5. Installation

5-1. Harness Application

5-1 TABLE 01

Interface	Used Voltage	Usage	Harness	Page
RS232/ Hopper/ Pulse	12~24V DC	Power & Data Comm.	WEL-RBD41	7
Hopper/ Pulse			WEL-RBD42	8
RS232/ Hopper/ Pulse			WEL-RBD46(optional)	9
RS232/ Hopper/ Pulse			WEL-RBD64(optional)	10

*Data Comm. : Data Communication.

Interface	Used Voltage	Usage
RS232/ Hopper/ Pulse	12~24V DC	Power &*Data Comm.

WEL-RBD41

- PIN 1- RED.....DC12V~DC24V
- PIN 2- WHITE.....GND
- PIN 3- BLUE.....EMPTY
- PIN 4- GRAY.....CREDIT_RELAY_NO
- PIN 5- ORANGE.....ERROR
- PIN 6- PURPLE.....DC12V~DC24V
- PIN 7- YELLOW.....GND
- PIN 8- GREEN.....PAYOUT
- PIN 9- BROWN.....CREDIT_RELAY_COM
- PIN 10- NC



MOLEX 5559-10P
BACK VIEW

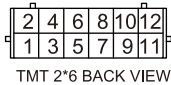
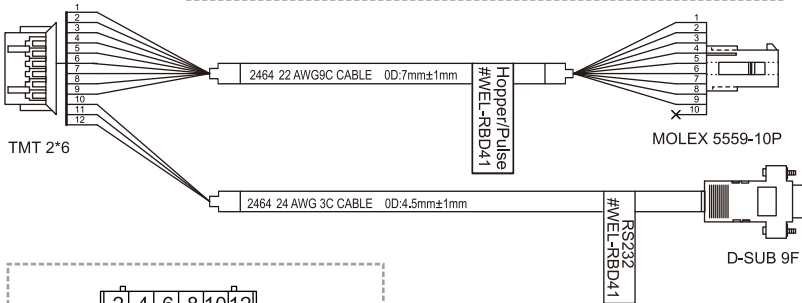

TMT 2*6 BACK VIEW

- PIN 1- RED.....DC12V~DC24V
- PIN 2- PURPLE.....DC12V~DC24V
- PIN 3- WHITE.....GND
- PIN 4- YELLOW.....GND
- PIN 5- BLUE.....EMPTY
- PIN 6- GREEN.....PAYOUT
- PIN 7- GRAY.....CREDIT_RELAY_NO
- PIN 8- BROWN.....CREDIT_RELAY_COM
- PIN 9- ORANGE.....ERROR
- PIN 10- BLACK.....GND
- PIN 11- WHITE.....PC-TX
- PIN 12- RED.....PC-RX

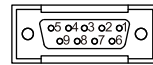



D-SUB 9F TOP VIEW

- PIN 2- RED.....PC-RX
- PIN 3- WHITE.....PC-TX
- PIN 5- BLACK.....GND

Interface	Used Voltage	Usage
Hopper/ Pulse	12~24V DC	Power &*Data Comm.

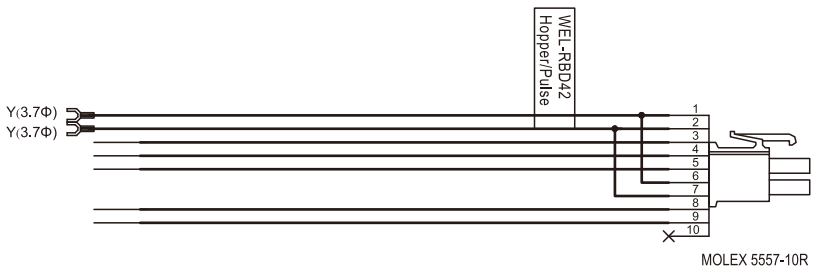
WEL-RBD42





MOLEX 5557-10R
BACK VIEW

PIN 1- RED.....DC12V-DC24V
 PIN 2- BLACK.....GND
 PIN 3- BLUE.....EMPTY
 PIN 4- GRAY.....CREDIT_RELAY_NO
 PIN 5- ORANGE.....ERROR
 PIN 6- RED.....DC12V-DC24V
 PIN 7- BLACK.....GND
 PIN 8- GREEN.....PAYOUT
 PIN 9- BROWN.....CREDIT_RELAY_COM

Interface	Used Voltage	Usage
RS232/ Hopper/ Pulse	12~24V DC	Power &*Data Comm.

WEL-RBD46 (Optional)

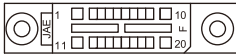
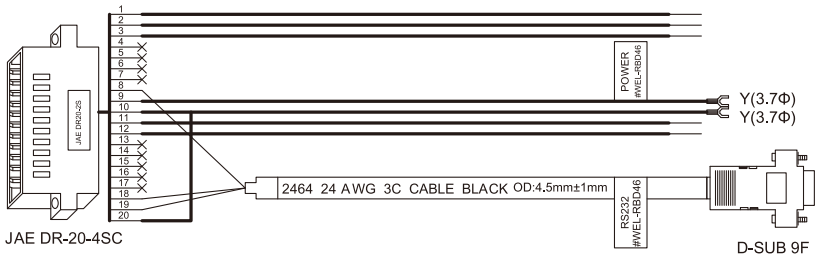

JAE DR-20-4SC BACK VIEW

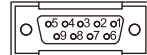

D-SUB 9F TOP VIEW

- PIN 1- GREEN.....EMPTY
- PIN 2- WHITE.....PAYOUT
- PIN 3- GRAY.....ERROR
- PIN 8- RED.....PC-RX
- PIN 9- BLACK.....GND
- PIN 10- RED.....DC12V~DC24V
- PIN 11- PURPLE.....CREDIT_RELAY_NO
- PIN 12- PINK.....CREDIT_RELAY_COM
- PIN 18- WHITE.....PC-TX
- PIN 19- BLACK.....GND
- PIN 20- RED.....DC12V~DC24V

- PIN 2- RED.....PC-RX
- PIN 3- WHITE.....PC-TX
- PIN 5- BLACK.....GND

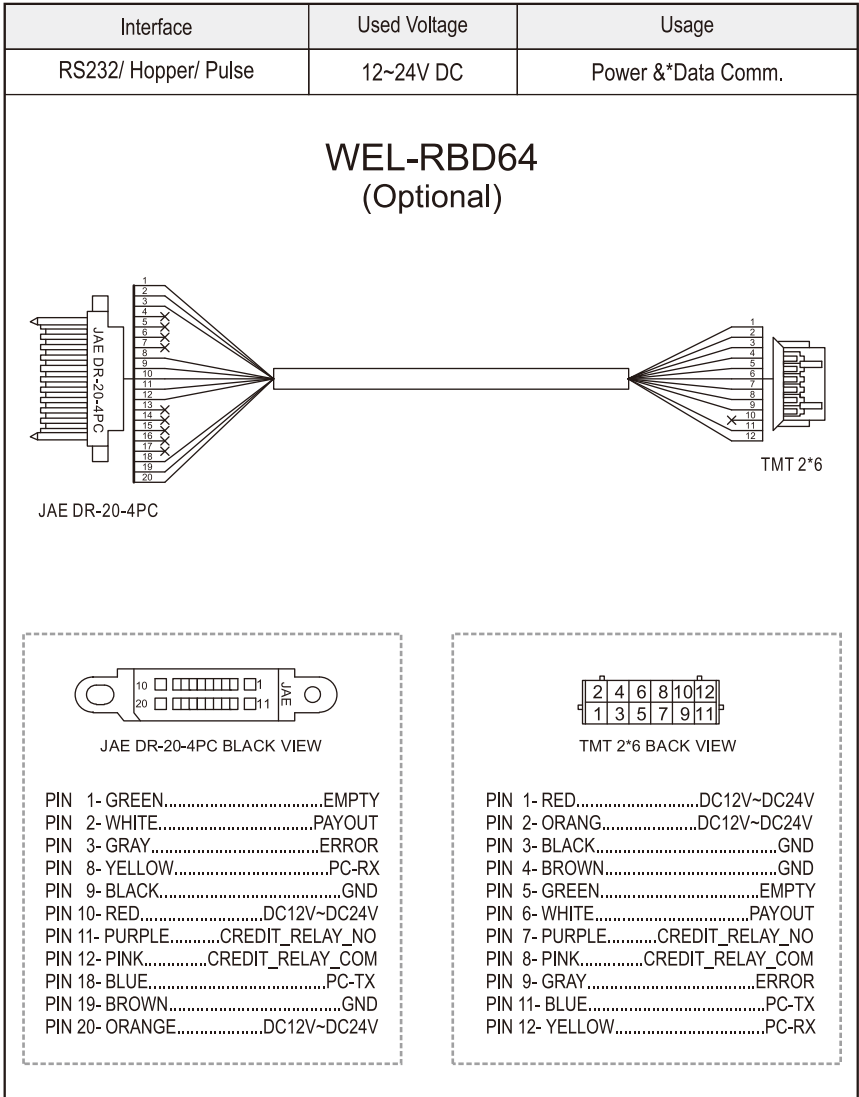

5-1-1. I/O Circuit

RS232 Interface.

5-1-1 FIG.01

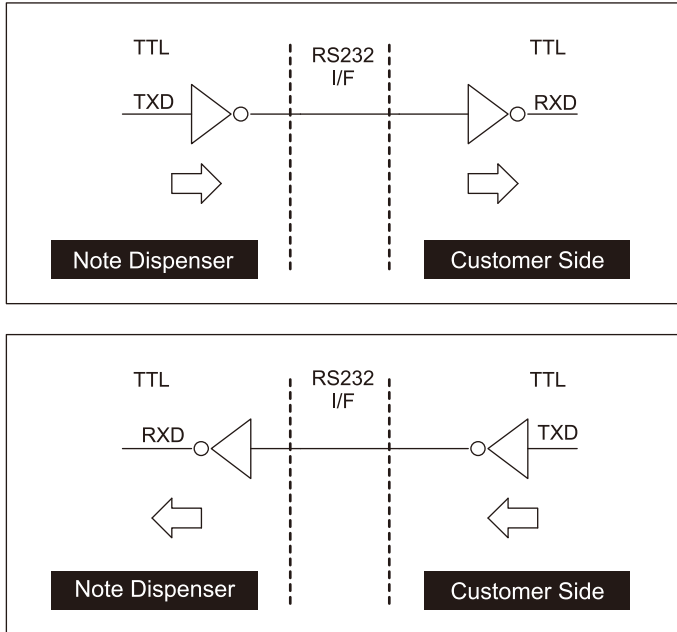

HOPPER/ PULSE I/F Interface.

5-1-1 FIG.02

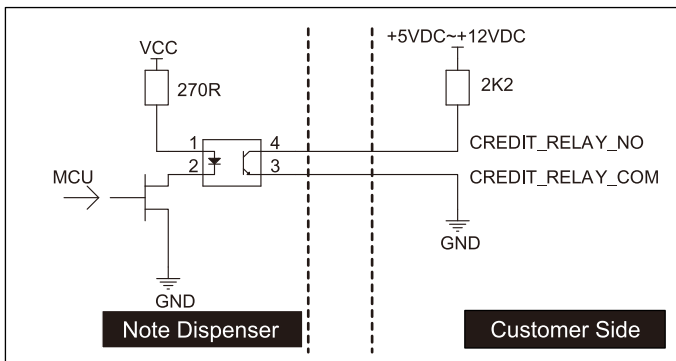
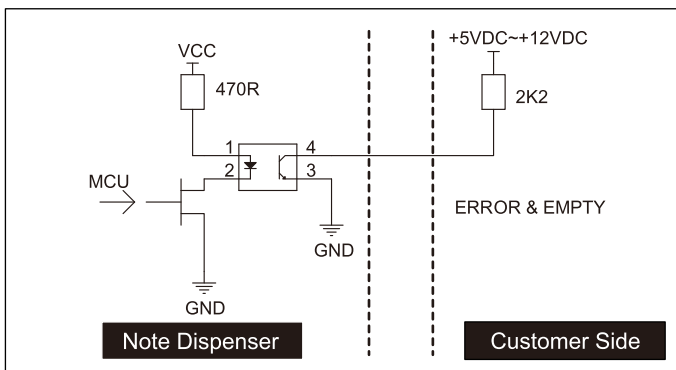
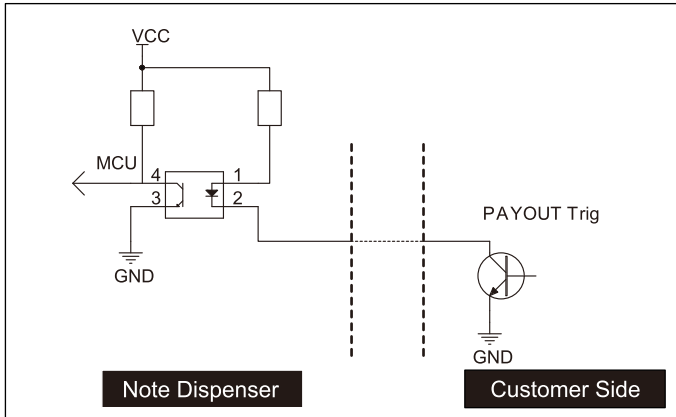

5-2. Key Function

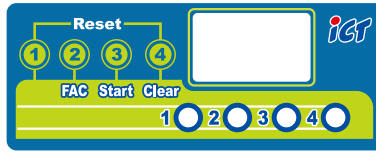

5-2 FIG.01-1

Key Setting	Function
<p>When the power is ON, the LED display shows Version No. For two seconds.(Ex. 0.10→00.7→003.)</p> <p>Pressing FAC Key 2 times</p>	<p>Enter into [Set up] Mode</p>
<p>Enter into [Set up] Mode</p> <p>Pressing FAC Key select item</p> <p>Pressing Start Key setting(+)</p> <p>Pressing Clear Key setting(-)</p>	<p>Enter into 1st Item ID number set up (ex.C00~C99).</p>
	<p>Enter into 2nd Item: set up regular dispensing quantity (ex.E01~10).</p>
	<p>Enter into 3rd item set up: Interface selection. When DIPSW SW1 OFF and SW2 ON, then IF0: Pulse IF1: Pulse and ICT104U IF2: ICT104U</p>
	<p>Enter into 4th item set up: Interface selection. When DIPSW SW1 ON SW2 ON, then gE0: Hopper gE1: Gamming</p>
	<p>Enter into 5th item set up: Face value ratio between banknote and coins A01: 1 coin face value = 1banknote face value A02: 2 coin face value = 1banknote face value Maximum A99</p>
	<p>Enter into 6th item set up: rc Pressing Start Key, clear the warning of cleaning required, and return to Standby Mode.</p>
<p>Enter into 7th item set up: Start key lock or unlock. SL0: unlock SL1: lock</p>	

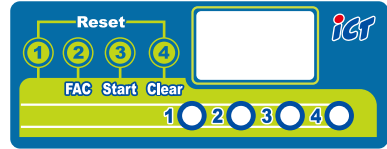

5-2 FIG.01-2

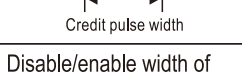
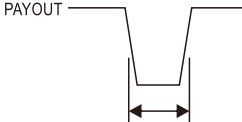
Key Setting	Function
Enter into [Set up] Mode Pressing FAC Key select item Pressing Start Key setting(+) Pressing Clear Key setting(-)	Enter into 8th item set up: Clear key lock or unlock. cL0: unlock cL1: lock
	Enter into 9th item set up: Bill value: cH1~cH8.
	Enter into 10th item set up: Judge function selection Jn0, Jn1(default)
	Enter into 11th item set up: Width of Pulse for credit signal. cr1: 50ms cr3: 150ms cr2: 100ms cr4: 200ms CREDIT_RELAY_NO normal open  CREDIT_RELAY_NO normal close  Credit pulse width
	Enter into 12th item set up: Disable/enable width of Pulse for payout signal. Pc0: Disable width of Pulse for payout signal Pc1: Enable width of Pulse for payout signal
Enter into 13th item set up: Width of Pulse for payout signal. PL1: 50ms (active low) PL2: 100ms (active low) PL3: 150ms (active low) PAYOUT  PAYOUT pulse width	

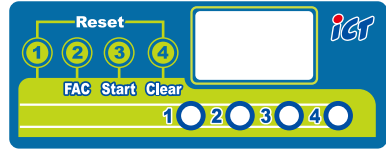

5-2 FIG.01-3

Key Setting	Function
Enter into [Set up] Mode Pressing FAC Key select item Pressing Start Key setting(+) Pressing Clear Key setting(-)	Enter into 14th item set up: r01: 1Pulse/ payout 1 bill r02: 1Pulse/ payout 2 bills maximum r50
	Enter into 15th item set up: Banknote Distinguish selection. bo0: normal banknote bo1: banknote with large window
	Enter into 16th item set up: EP0~EP1 Need a password to use the button or not. EP0: No password required to use the button EP1: Password required to use button
	Enter into 17th item setup: Sc0~Sc2 Sc0: normal speed dispensing Sc1: slow speed dispensing Sc2: very slow speed dispensing
	Enter into 18th item setup: JL0~JL1 JL0: standard bill width tolerance JL1: extended bill width tolerance
	Enter into 19th item set up: S Pressing Start Key, Save changed setup, and return to Standby Mode.

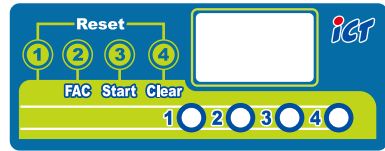

5-2.FIG.02

Button lock instructions	Description
Button lock	Lock the button to avoid misoperation, you need to unlock it to use the button function according to the table below.
Password to unlock button	Press 2 3 1 1 in sequence
Unlock time limit	< 5 seconds
The time the button can be used after unlocking	10 seconds Enter into [Set up] mode is not limited by 10 seconds.
Key Setting	Function
Learning Mode Pressing FAC Key 3 seconds	Make sure there are at least 20 banknotes inside of NDE1000, and enter into [Learning] Mode Return to Standby Mode when Learning finished.
Standby Mode Pressing Start Key 3 seconds	Regular dispensing
Standby Mode Pressing Clear Key 3 seconds	Clear the number of Non-automatic dispensed.
Pressing 1 and Clear key	Reset NDE1000/ Escape [Set up] Mode.
After clearing of fault Pressing Clear Key 2 times	Clear error code .

Display screen would show the number how many banknotes dispensed by manual Total three digits shown on the screen, digits, tens, hundreds.

It would show the point"." in case of the number over 999,

For example, "999." means 1999, "99.9" means 2999, "9.99" means 3999.

Please check the trouble shooting table when NDE1000 have any error occurred.(Refer to 8-1. Error Messages)

5-3. DIP Switch Setting

You can see a DIP-SW at the backside of NDE1000 for you to set up, for example, the interface, function settings, etc. Please check the dip-switch setting manual for details.

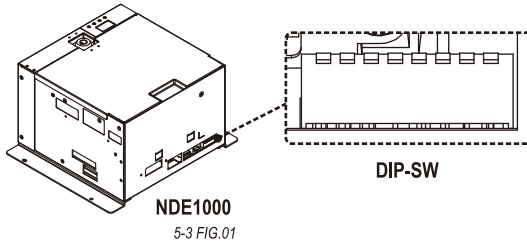

5-4. Software Download and Upgrade

5-4-1. ICT FP-004 Programmer Firmware Upgrade

There are three ways to download and upgrade the software to NDE1000. Please contact ICT to purchase FP-004 and refer to FP-004 user guide for software upgrade information.

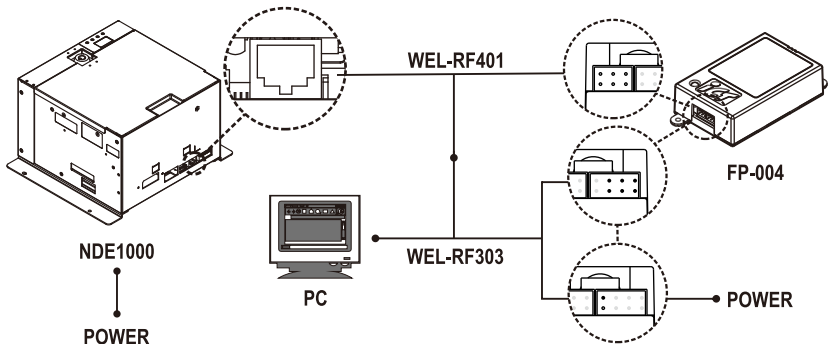

Please turn off the power of NDE1000 before connecting the FP-004.

5-4-2. USB Pen Drive Firmware Upgrade

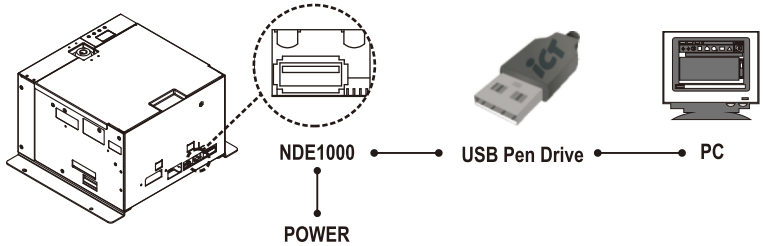

Please turn off the power of NDE1000 before connecting the USB pen drive.

Step 1.

Please load the software(**NDEX#SXXXXIBBBBXXXXX.bin**) into USB pen drive through PC.

Step 2.

Turn on the power after connecting the USB pen drive to the USB Port of NDE1000.

Step 3.

It shows from  turn to  means download finished.

Unplug USB pen drive and then NDE1000 will automatically back to standby mode.

5-4-3. ICT MTB Firmware Upgrade

Step 1.

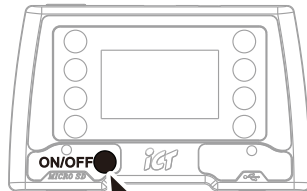

Turn on the power of MTB.

Step 2.

Use the download cable WEL-RHP57 connecting to PC.

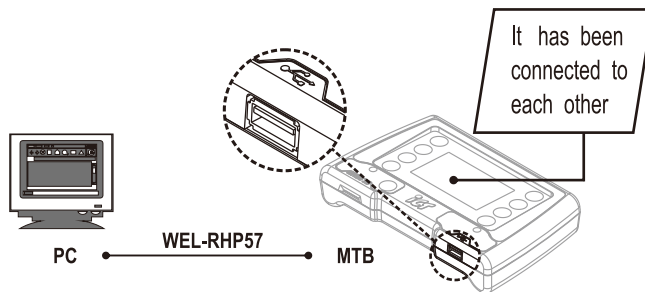

Step 3.

Please load the software(**NDEX#SXXXIBBBBXXXXX.bin**) into MTB through PC.

Step 4.

Turn on the power after MTB is connected with NDE1000.

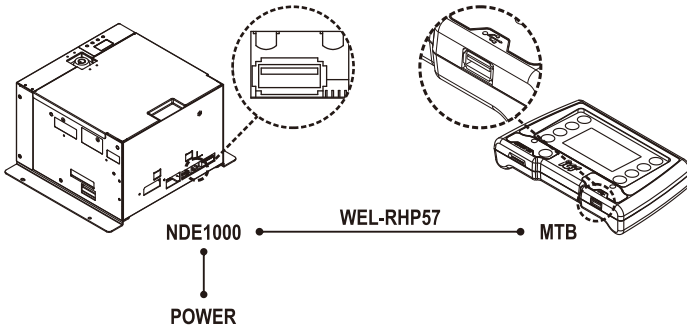

 Please turn off the power of NDE1000 before connecting the MTB.

Step 5.

It shows from  to  means the download finished.

Unplug MTB and then NDE1000 will automatically back to standby mode.

6. Operation



6-1. Unusable Note

Mixing up different denominations or currencies may cause double banknotes output due to different banknote form and material. In addition, the following type of notes are prohibited.

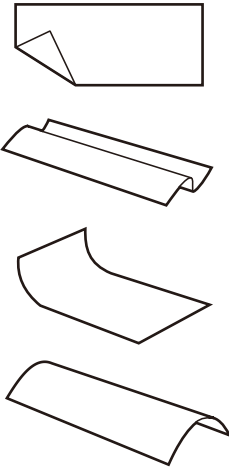
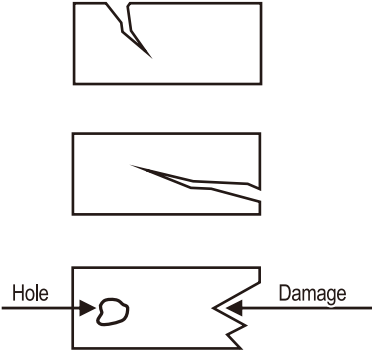
6-1 TABLE.01

Type	Diagram	Solution
<p>Curled or wrinkled notes</p>		<p>Unfold the note</p>
<p>Broken notes</p>		<p>Prohibited</p>

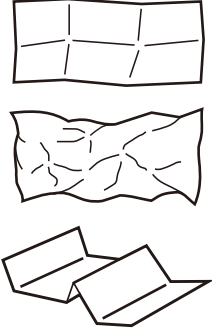
6-1 TABLE.01-1

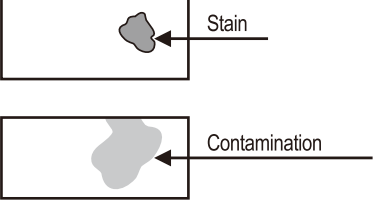
Type	Diagram	Solution
Curled or wrinkled notes		Prohibited
Taped notes		Prohibited
Dirty notes		Prohibited

6-2. How to Fill Notes

1. Open the upper cover, loosen a screw and take the fixing plate out.

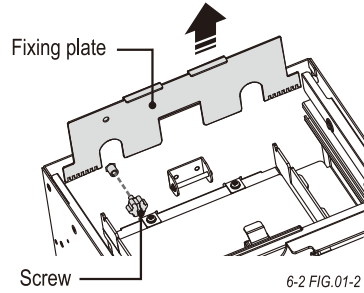
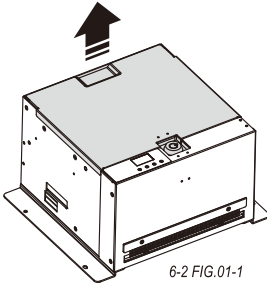

2. Move the plates to the both sides, and fix the banknote plate on the back side.

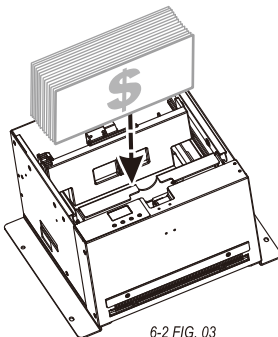
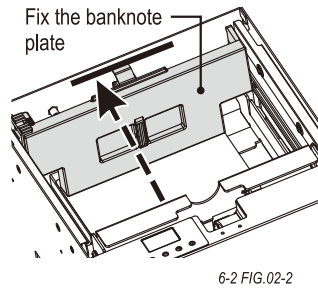
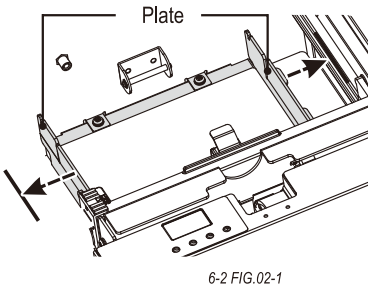

3. After filling into the banknotes, please adjust the plates to close to the wide-size edge of banknotes.

4. Plug in the fixing plate and fasten a screw.

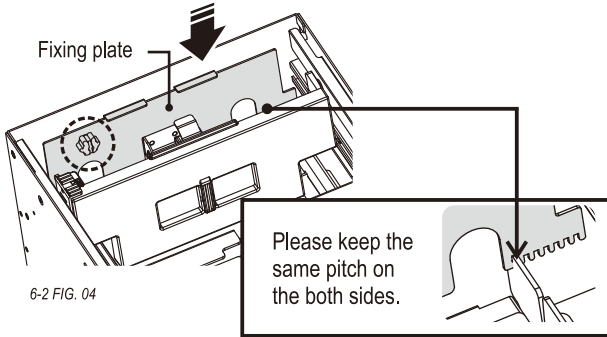

6-3. Low Level Adjustment

To open the cover, you can set up the threshold of low capacity with the number of 15/35/55.

Ex. Adjust the plate to select “35” of the threshold value, and the display would show **LOB** for low-level alert when banknotes lower than approx.35 notes.

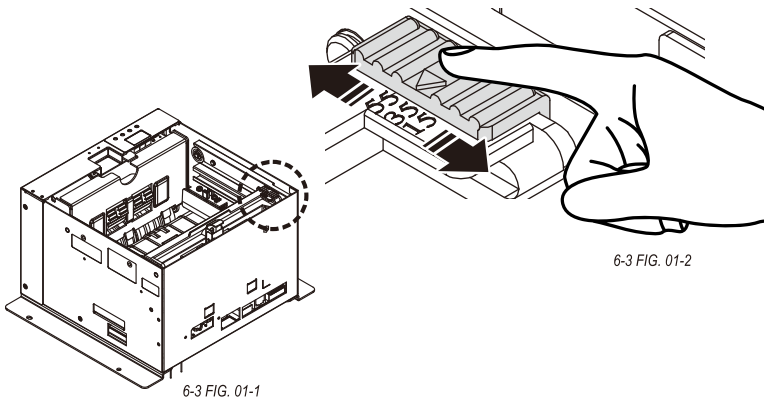

7. Maintenance

To make sure the machine works normally, please be sure to clean up NDE1000 after some period of time.

Please follow the steps below:

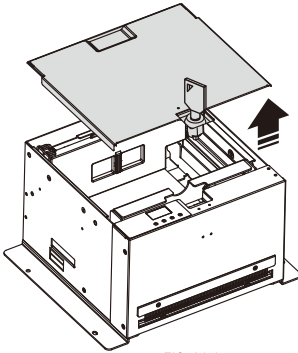

7 FIG. 01-1

1. Unlock the upper cover plate and using the air gun or brush to wipe out the dust inside NDE1000.

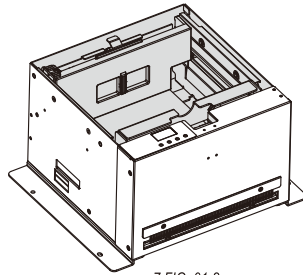

7 FIG. 01-2

2. Use a screwdriver to loose 5 screws and disassemble the front cover. Be sure to secure the cables connections during cleaning up the device.

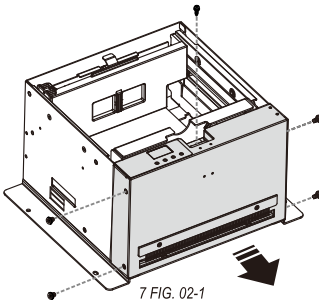

7 FIG. 02-1

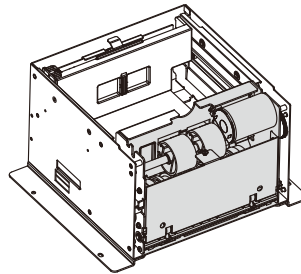











7 FIG. 02-2

	Maintenance Notice	
	<i>(Any improper maintenance will result invalid warranty.)</i>	
	Recommended	Mild, non-abrasive, soap water.
	DO NOT USE	Organic solvent , Alcohol, Volatile liquid.

8. Troubleshooting









8-1. Error Messages

8-1 TABLE 01

Code	Diagram	Status	Solution
FrE		Component failure	Contact ICT for help.
AtE			
dAE			
FLE			
LoV		Low voltage	Replace the power supply with standard voltage noted in the specification then the error code will disappear.
HIV		High voltage	
IrE		Sensor problem	Contact ICT for help.
nob		Out of banknote	Please fill in banknotes, and press the Clear key twice then the error code will disappear.
cHA		Banknote(width/length) abnormal	Clean out the dust inside of NDE1000, and press the Clear key twice then the error code cancelled.
db		Double notes	
HAL		Half note	

 If the error can not be solved after corrective actions or happen again, please contact ICT for technical support.

8-1 TABLE 02

Code	Diagram	Status	Solution
Jan		Banknote jammed	Clean out the dust inside of NDE1000, and press the Clear key twice then the error code cancelled.
Lob		Low level alert	Please add in banknotes.
		 Upon receiving a low level alert, please replenish the cash supply promptly. Otherwise, the current transaction may not be completed if there is insufficient cash available for dispensing.	
LrE		Learning error	Make sure there are at least 20 banknotes inside NDE1000, and try the study mode again.
clr		Alert to clean	Please follow step 7 to clean NDE1000, entry setting mode, Press the FAC key several times until the " rc " item is displayed, then press the Start key, then the error code cancelled.
doc		Manual dispense exceed max. number recorded (3999 notes)	Keep pressing the Clear key for three seconds and the figure returns to zero.
E01		Motor problem	Contact ICT for help.
E12		Motor problem	Contact ICT for help.



If the error can not be solved after corrective actions or happen again, please contact ICT for technical support.

ict Taiwan

International Currency Technologies Corporation

No.28, Ln. 15, Sec. 6, Minquan E. Rd., Neihu Dist., Taipei City 114, Taiwan

sales@ictgroup.com.tw (For Sales)

fae@ictgroup.com.tw (For Customer Service)

Website: www.ictgroup.com.tw

