



Bill Acceptor
PA7E
Installation Guide



International Currency Technologies Corp.

Use of Materials Limitations

International Currency Technologies Corporation (ICT) all rights reserved.

All materials contained are the copyrighted property of ICT.

All trademarks, service marks, and trade names are proprietary to ICT.

ICT reserves the right at all times to disclose or to modify any information as ICT deems necessary to satisfy any applicable law, regulation, legal process or governmental request, or to edit, refuse to post or to remove any information or materials, in whole or in part, in ICT's sole discretion.

Contents

1. Introduction	
1-1. Overview	2
1-2. Features	2
2. Specifications	2
3. Packing List	3
4. Dimension	4
4-1. Bezel Style	5
5. Installation	
5-1. Harness Application	6
5-1-1. I/O Circuit	16
5-2. DIP Switch Setting	21
5-3. Firmware Download and Upgrade.....	21
6. Maintenance	22
7. Troubleshooting	
7-1. Bezel LED Errors	23
7-2. Back LED Errors	24
7-3. USB Firmware Upgrade LED Errors.....	24

1. Introduction

1-1. Overview

PA7E is a bill acceptor which features as high-security with acceptance rate up to 96% or even greater. The built-in USB port allows convenient firmware upgrades via USB flash drive.

1-2. Features

- Easy Maintenance.
- Four-way bill insertion acceptance.
- Bill box capacity: 400, 500 and 800 bills available.
- Convenient firmware upgrade via USB flash drive.
- Auto-calibration technology and dual-color identification LED.

2. Specifications

General

Acceptance Rate 96% or greater

Note: The acceptance rate excludes notes that are dirty, wet, broken or wrinkled.

Bill Insertion Four-way acceptable

Transaction Speed Approx. 3 seconds to stack

Interface Pulse, ICT Protocol, NISR, 5V Enable

Electrical

Power Source 12V DC(10.8~13.2V DC)
117V AC(105.3~128.7V AC)

Power Consumption	12V DC Standby : 0.3A, 3.6W Operation: 0.9A, 11W Maximum: 2.5A, 30W 117VAC Standby : 0.05A, 5.85W Operation: 0.112A, 13W Maximum: 0.3A, 35W
Operation Environment	Operation Temperature: 0°C~55°C Storage Temperature: -30°C~70°C Humidity: 30%~85% RH(no condensation)

Mechanical

Bill Width	62~72mm
Bill Capacity	Approx. 400 bills(300~400) 500 bills(400~500) 800 bills(700~800)
Weight	Approx. 1.3kg
Outline Dimension	Refer to page.4



Installation: Indoor use only!!

3. Packing List

Main	Bill Acceptor
Accessory	Harness: Refer to 5-1 PA7E Installation Guide PA7E DIP Switch Setting Guide

4. Dimension

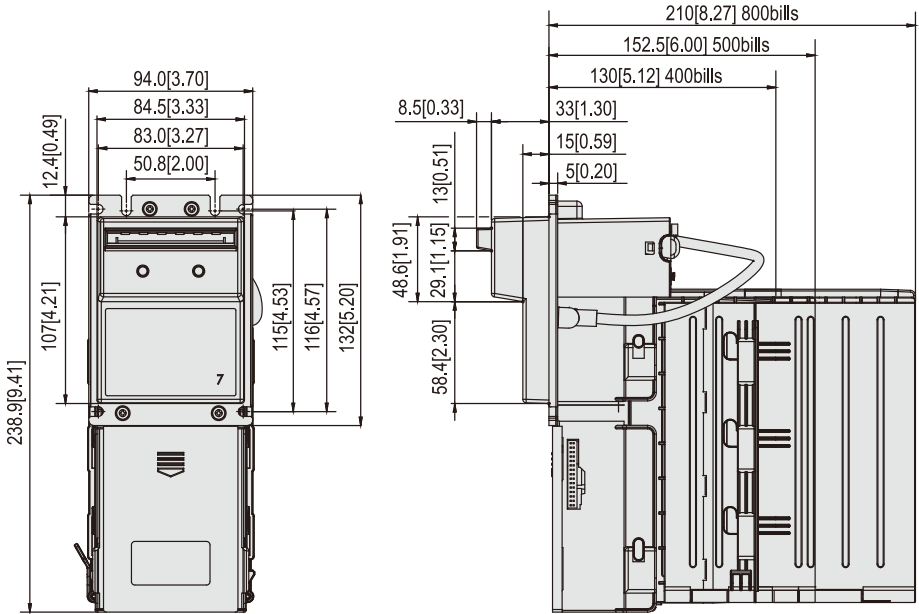

Unit:mm[inch]

4 FIG.01

4-1. Bezel Style

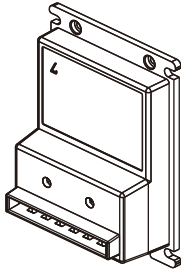

4-1 FIG.01

Compact Bezel

Part Number: A2209X00-R

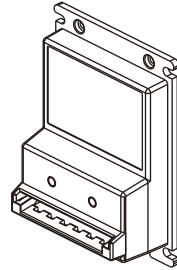

4-1 FIG.02

Bezel (Step Style)

Part Number: A3025X00-R

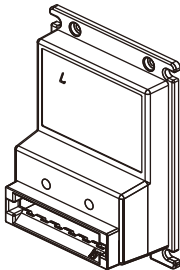

4-1 FIG.03

Two Sided Bezel

Part Number: A2422X00-R

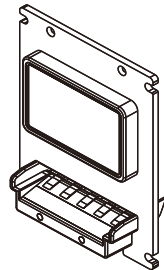

4-1 FIG.04

Horizontal Stacker Bezel

Part Number: A2426X-R

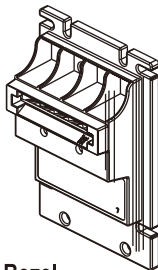

4-1 FIG.05

TOB Bezel

Part Number: A2582X00-R

5. Installation

5-1. Harness Application

5-1 TABLE 01

Interface		Used Voltage	Usage	Harness	Page
Pulse	12VDC	Power & *Data Com.	WEL-RM044	7	
		Extension Wire	CU-R961-1	8	
	117VAC	Power & *Data Com.	WEL-RM045	9	
		Extension Wire	WEL-RM012	10	
Pulse+5V Enable	117VAC	Power & *Data Com.	WEL-RM047	11	
		Extension Wire	WEL-RM018	12	
NISR		117VAC	Power & *Data Com.	2-BA-RM046	13
ICT Protocol	RS232	12V DC	Power	WEL-RM044	7
			Extension Wire	CU-R961-1	8
			*Data Comm.	WEL-RV706-1 or 2-BA-RV706	14
		117V AC	Power	WEL-RM045	9
			Extension Wire	WEL-RM012	10
			*Data Comm.	WEL-RV706-1 or 2-BA-RV706	14
	USB	12V DC	Power	WEL-RM044	7
		117V AC	Power	WEL-RM045	9
		5V DC	*Data Com.	WEL-RHP57 (Optional)	15

*Data Com. : Data Communication.

5-1 FIG.01

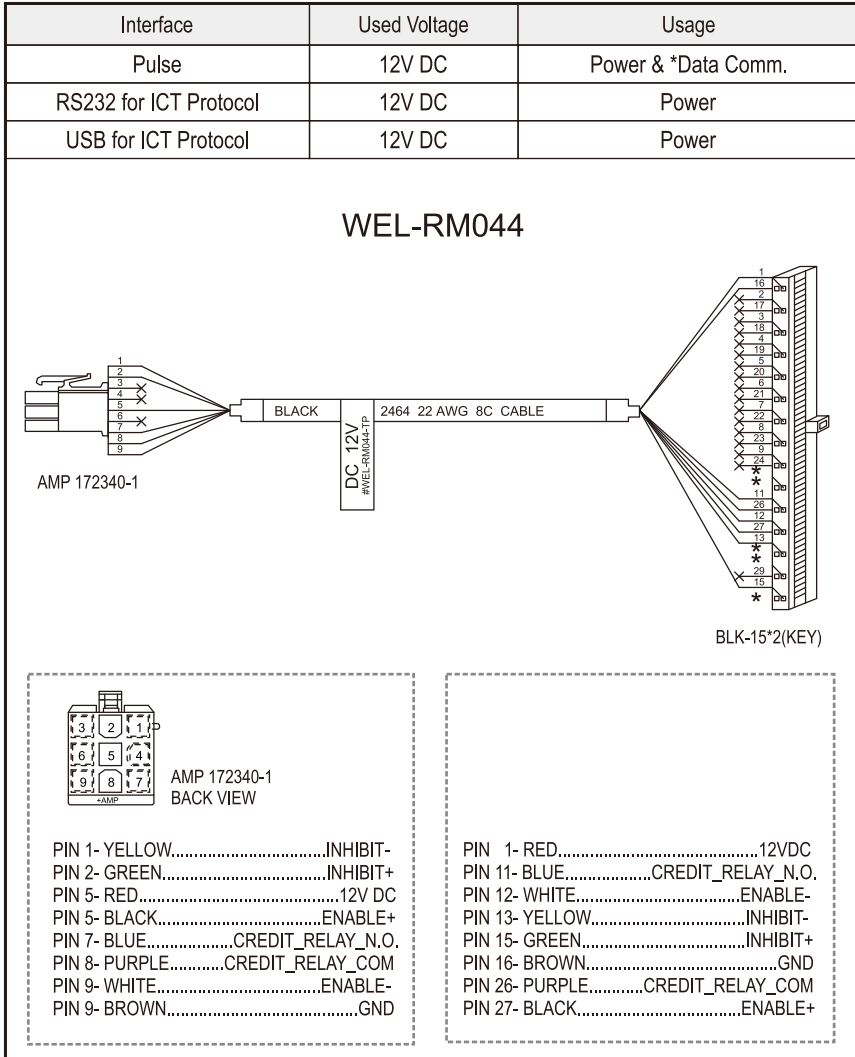

Interface	Used Voltage	Usage
Pulse	12V DC	Extension Wire for WEL-RM044
RS232 for ICT Protocol	12V DC	Extension Wire for WEL-RM044

CU-R961-1

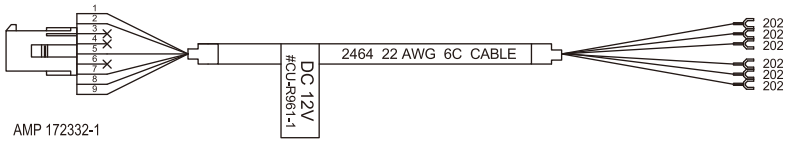

AMP 172332-1

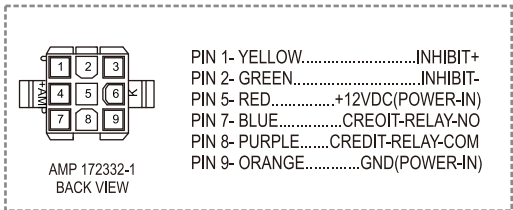

5-1 FIG.03

Interface	Used Voltage	Usage
Pulse	117V AC	Power & *Data Comm.
RS232 for ICT Protocol	117V AC	Power
USB for ICT Protocol	117V AC	Power

WEL-RM045

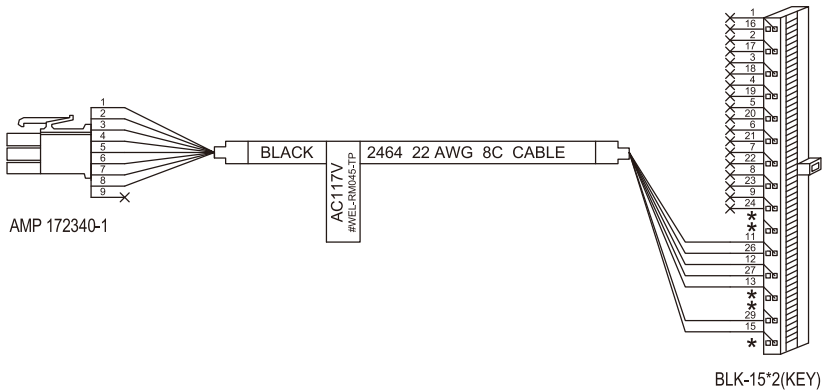

AMP 172340-1

BLACK
AC117V
#WEL-RM045-TP
2464 22 AWG 8C CABLE

BLK-15*2(KEY)

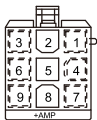

AMP 172340-1
BACK VIEW

- PIN 1- YELLOW.....NEUTRAL_INHIBIT
- PIN 2- RED.....NEUTRAL_ENABLE
- PIN 3- BROWN.....HOT_ENABLE
- PIN 4- BLACK.....115VAC_HOT
- PIN 5- GREEN.....RESERVE
- PIN 6- WHITE.....115VAC_NEUTRAL
- PIN 7- BLUE.....CREDIT_RELAY_N.O.
- PIN 8- PURPLE.....CREDIT_RELAY_COM

- PIN 11- BLUE.....CREDIT_RELAY_N.O.
- PIN 12- RED.....NEUTRAL_ENABLE
- PIN 13- YELLOW.....NEUTRAL_INHIBIT
- PIN 15- BLACK.....115VAC_HOT
- PIN 26- PURPLE.....CREDIT_RELAY_COM
- PIN 27- BROWN.....HOT_ENABLE
- PIN 29- WHITE.....115VAC_NEUTRAL

Interface	Used Voltage	Usage
Pulse	117V AC	Extension Wire for WEL-RM045
RS232 for ICT Protocol	117V AC	Extension Wire for WEL-RM045

WEL-RM012

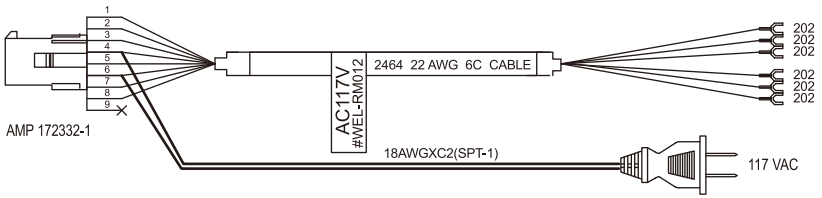

AMP 172332-1 BACK VIEW

PIN 1- YELLOW.....NEUTRAL INHIBIT
 PIN 2- RED.....NEUTRAL ENABLE
 PIN 3- ORANGE.....HOT ENABLE
 PIN 4- BLACK.....17VAC HOT (Power)
 PIN 5- GREEN.....Earth - Ground
 PIN 6- BLACK.....117VAC NEUTRAL (Power)
 PIN 7- BLUE.....CREDIT_RELAY (N.O.)
 PIN 8- PURPLE.....CREDIT_RELAY (Common)
 PIN 9- Reserved

202

YELLOW.....NEUARAL INHIBIT
 RED.....NEUTRAL ENABLE
 ORANGE.....HOT ENABLE
 GREEN.....Earth - Ground
 BLUE.....CREDIT_RELAY (N.O.)
 PURPLE.....CREDIT_RELAY (Common)

5-1 FIG.05

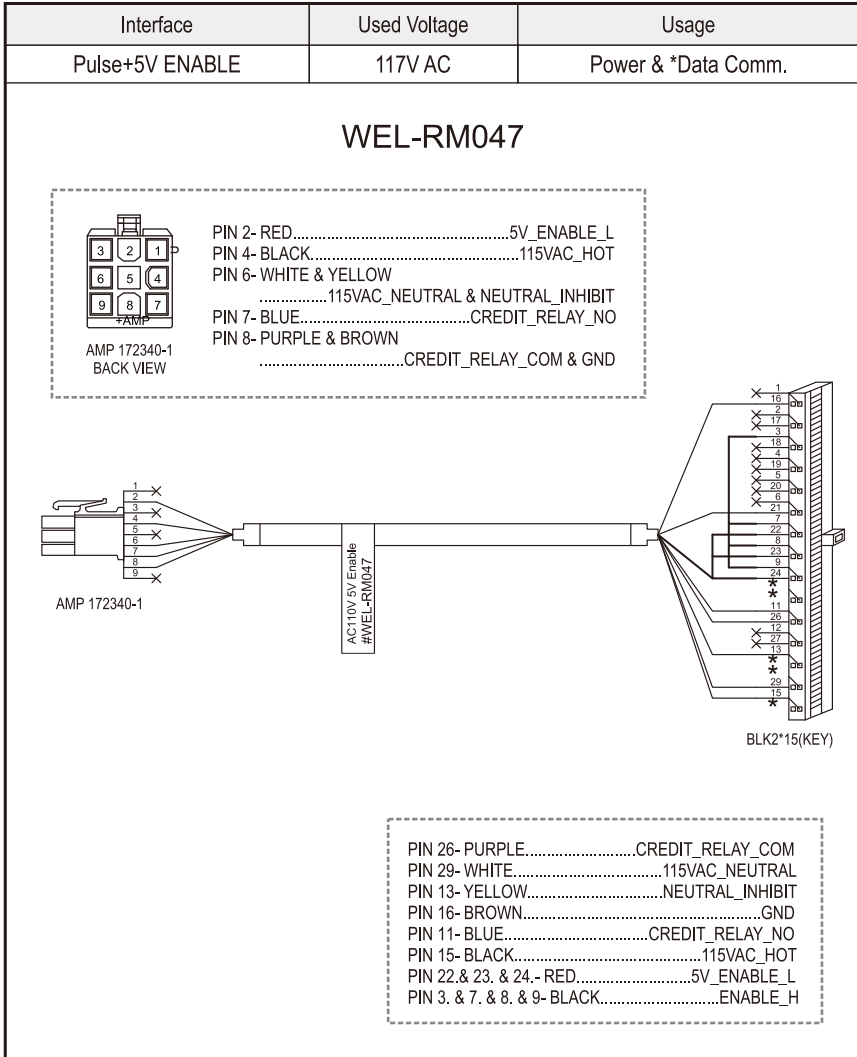

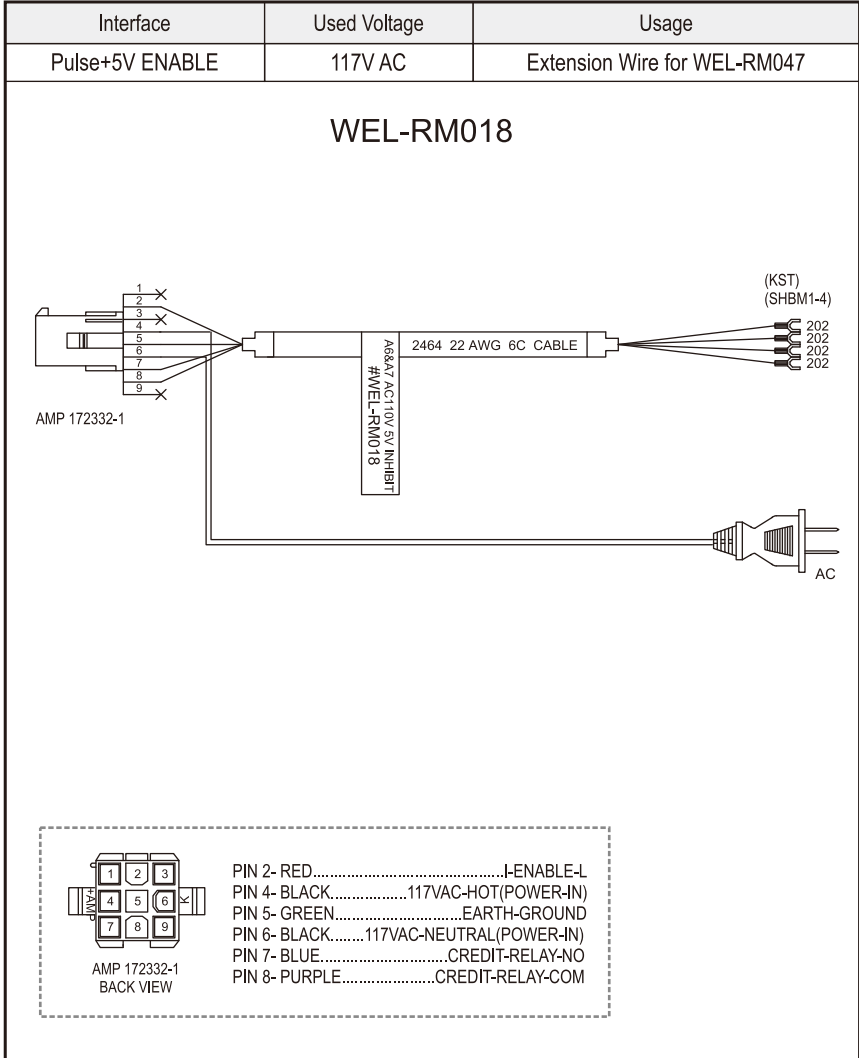

5-1 FIG.07

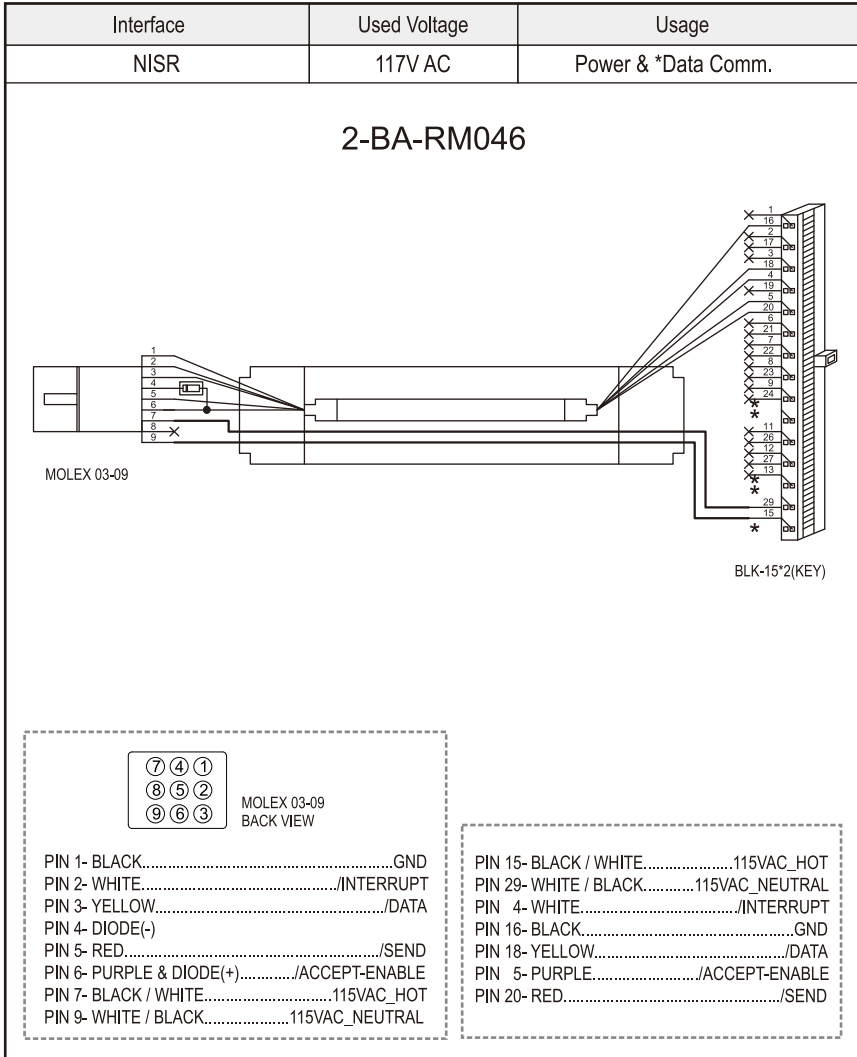

Interface	Used Voltage	Usage
RS232 for ICT Protocol	12V DC	*Data Comm.
RS232 for ICT Protocol	117V AC	*Data Comm.

WEL-RV706-1

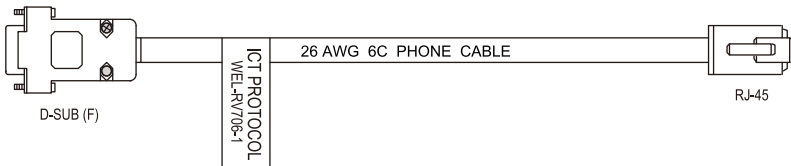

2-BA-RV706

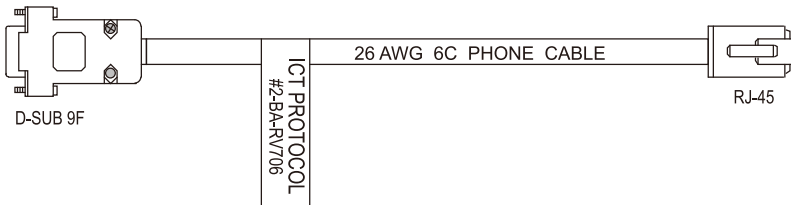

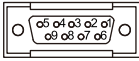

D-SUB 9F TOP VIEW

- PIN 1- RESERVED
- PIN 2- RXD
- PIN 3- TXD
- PIN 4- RESERVED
- PIN 5- GND
- PIN 6- RESERVED
- PIN 7- RESERVED
- PIN 8- RESERVED
- PIN 9- RESERVED

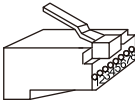

RJ-45 VIEW

- PIN 1- BLUE.....GND
- PIN 2- YELLOW.....TX22
- PIN 3- GREEN.....RX22
- PIN 4- X.....RESERVED
- PIN 5- X.....RESERVED
- PIN 6- RED.....VCC
- PIN 7- BLACK.....RX11
- PIN 8- WHITE.....TX11

5-1-1. I/O Circuit

Pulse Interface.

5-1-1 FIG.01

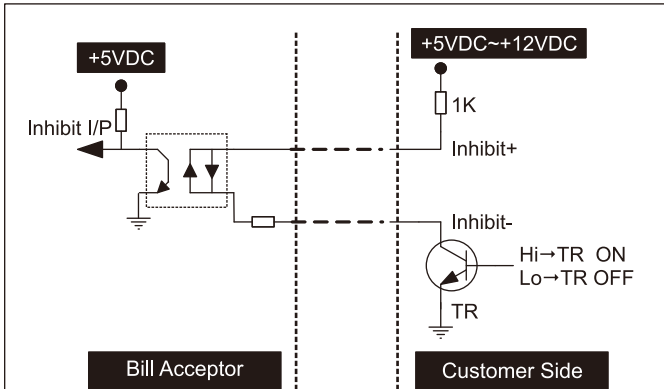
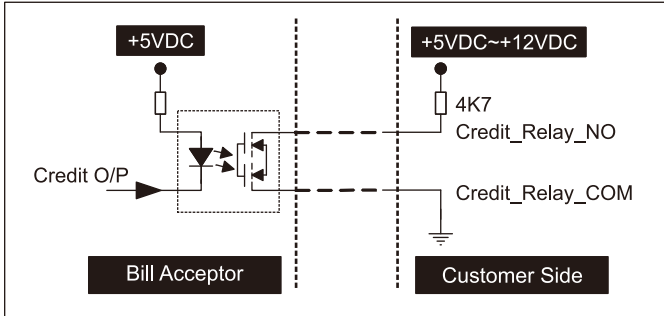

BA Status	*DIP SW Setting	Control Signal
Inhibit	Inhibit Active	Low
		High
Enable	Inhibit Active	Low
		High

**Note: Please refer to DIP Switch Setting Guide for detail.*

ICT Protocol Interface.

5-1-1 FIG.02

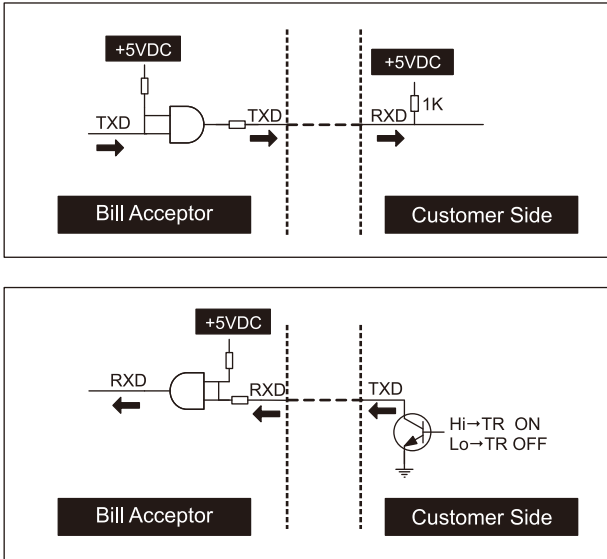

5V Enable Interface-1.

5-1-1 FIG.03-1

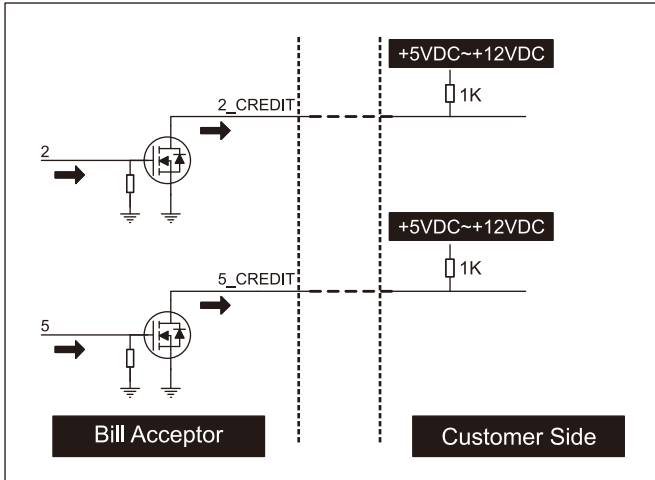

5V Enable Interface-2.

5-1-1 FIG.03-2

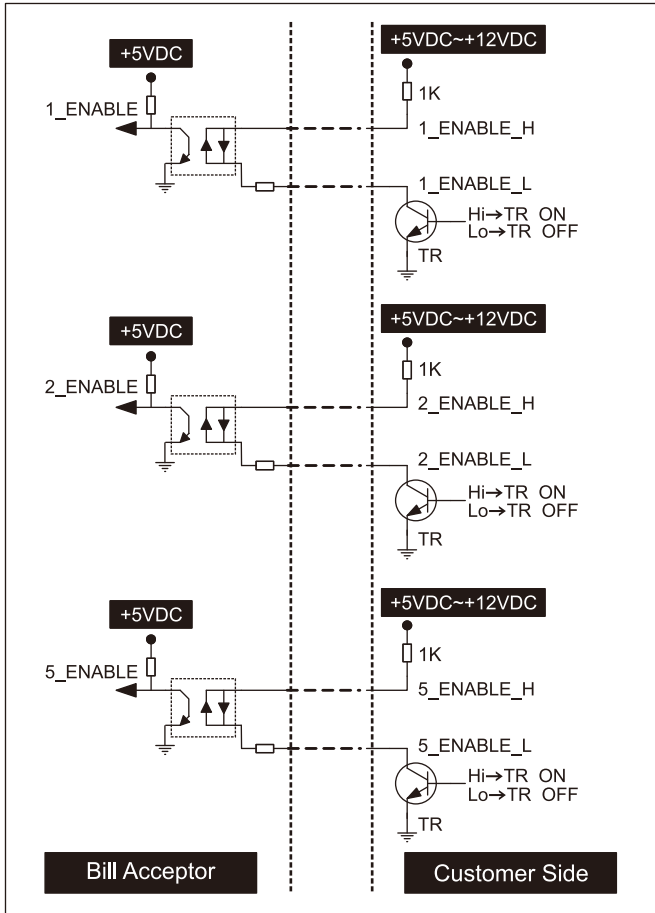

NISR Interface.

5-1-1 FIG.04

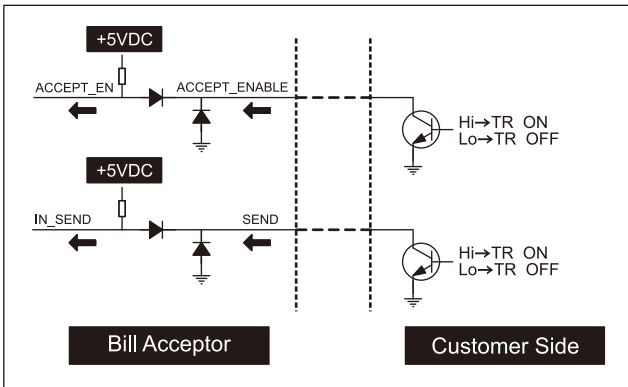
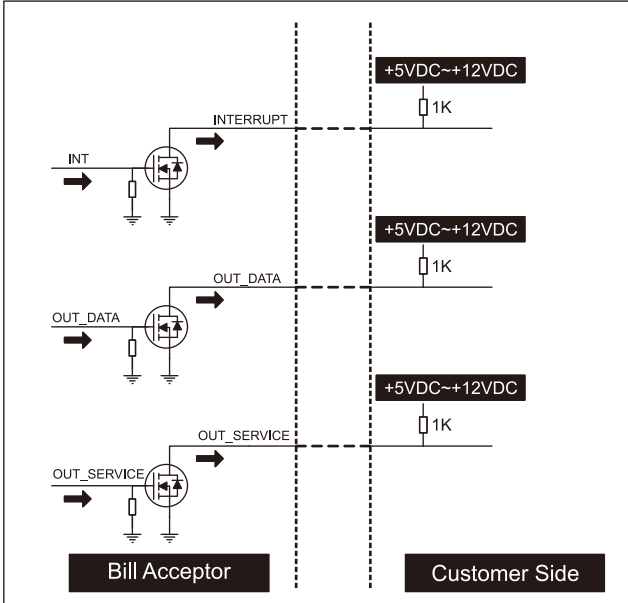

5-2. DIP Switch Setting

There are two serial DIP switches which are located on the side of PA7E(as FIG.01). According to different currencies which are used by users, DIP switch settings could be varied to fit users' needs. Besides, there's also a serial DIP switches on CPU board inside of PA7E for interface settings (as FIG.02).

Please refer to "PA7E DIP Switch Setting Guide" in the package for more details.

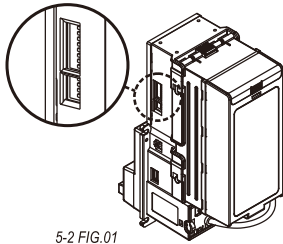

5-2 FIG.01

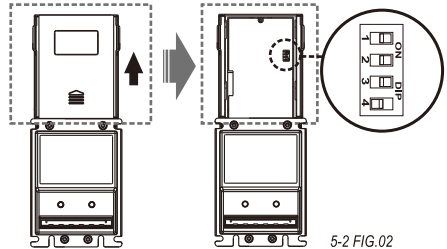

5-2 FIG.02

5-3. Firmware Download and Upgrade

Step 1. Put the "A7Exxx.bin" file into your USB Pen Drive.



Step 2. Turn off PA7E, plug the USB Pen Drive into the USB connector on the PA7E and then turn on the PA7E.

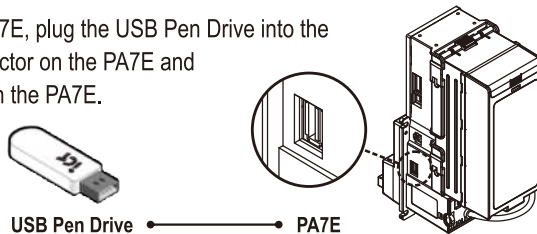

Step 3. The LED in the front side of bezel will flash twice, then remove the USB Pen Drive from PA7E.

Step 4. Wait for about 30sec., Then PA7E will automatically reset and standby for normal operation.

6. Maintenance

To make sure the bill acceptor always works smoothly, please clean the internal parts regularly.

To clean the internal parts:

1. Press the buttons on the sides of bill path unit and pull the unit out.

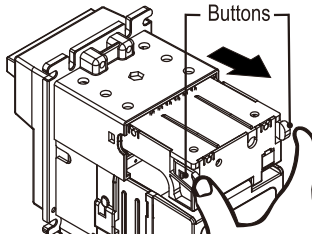

6 FIG.01

2. Use a soft, dry cloth or towel to clean the bill path and sensors.

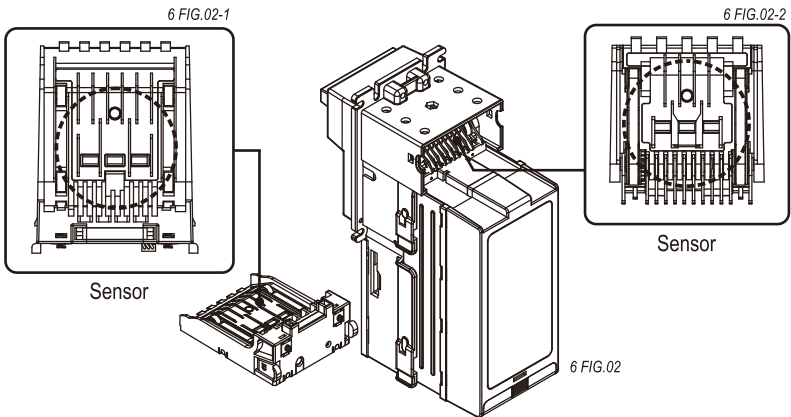

	Maintenance Notice	
	<i>(Any improper maintenance will result invalid warranty.)</i>	
Recommended	Mild, non-abrasive, soap water.	
DO NOT USE	Organic solvent , Alcohol, Volatile liquid.	

7. Troubleshooting

7-1. Bezel LED Errors

7-1 TABLE 01

LED	Status	Correct Actions
GREEN	White Card Calibration.	Please calibrate with ICT white calibration card.

7-1 TABLE 02

LED Flashes	Status	Correct Actions
RED		
1	Bill jammed.	Remove the bill box by sliding the top button and the bill path(as 7-1 FIG.02), and then remove the jammed bill.
2	Disable.	Inspect the right DIP switch setting.
3	Recognition sensor module error.	Inspect the foreign objects on sensor or bill path and clean.
3+2	Hook sensor error.	Inspect the foreign objects on security hook and clean.
4	A stringing attempt has detected.	Inspect the foreign objects on sensor or bill path and clean.
5	Bill box has been removed.	Replace the bill box.
6	Stacker error or stacker full.	Empty the bill box.
7	Motor error.	Inspect the foreign objects on bill path and clean.

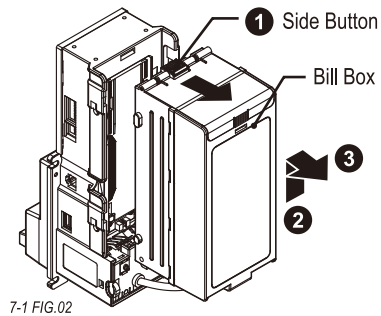
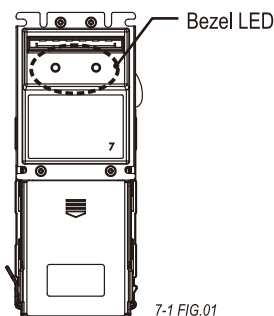

If the error can not be solved after corrective actions or happen again, please contact ICT for technical support.

7-2. Back LED Errors

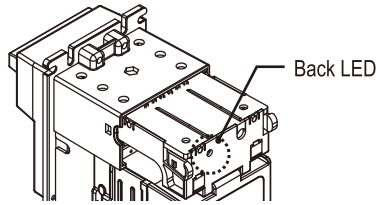

7-2 TABLE 01

LED Flashes	Status	Correct Actions
RED		
1	Bill jammed.	Remove the bill box by sliding the top button and the bill path(as 7-1 FIG.02), and then remove the jammed bill.
2	Disable.	Inspect the right DIP switch setting.
3	Recognition sensor module error.	Inspect the foreign objects on sensor or bill path and clean.
3+2	Hook sensor error.	Inspect the foreign objects on security hook and clean.
4	A stringing attempt has detected.	Inspect the foreign objects on sensor or bill path and clean.
5	Bill box has been removed.	Replace the bill box.
6	Stacker error or stacker full.	Empty the bill box.
7	Motor error.	Inspect the foreign objects on bill path and clean.

7-3. USB Firmware Upgrade LED Errors

7-3 TABLE 01

LED Flashes	Status	Correct Actions
RED		
1	USB Firmware Upgrade Errors.	<ol style="list-style-type: none"> 1. Make sure the USB if you can be normal to read. 2. Make sure USB in the program are correct.



If the error can not be solved after corrective actions or happen again, please contact ICT for technical support.

ict Taiwan

International Currency Technologies Corporation

No.28, Ln. 15, Sec. 6, Mincuan E. Rd., Neihu Dist., Taipei City 114, Taiwan

sales@ictgroup.com.tw (For Sales)

fae@ictgroup.com.tw (For Customer Service)

Website: www.ictgroup.com.tw

